

Technical data sheet

Mounting device

Part no.: 50025570

BT 96

Contents

- Technical data
- Dimensioned drawings
- Accessories



Figure can vary

Technical data

Basic data

Suitable for	96B series sensors
--------------	--------------------

Mechanical data

Standard designation, metal mounting device	Steel, galvanized
Design of mounting device	Angle, L-shape
Type of fastening, at system	Through-hole mounting
Type of fastening, at device	Screw type
Type of mounting device	Rigid
Mounting device material	Metal

Classification

Customs tariff number	73182900
eCl@ss 5.1.4	27279202
eCl@ss 8.0	27279202
eCl@ss 9.0	27273701
eCl@ss 10.0	27273701
eCl@ss 11.0	27273701
ETIM 5.0	EC002498
ETIM 6.0	EC003015
ETIM 7.0	EC003015

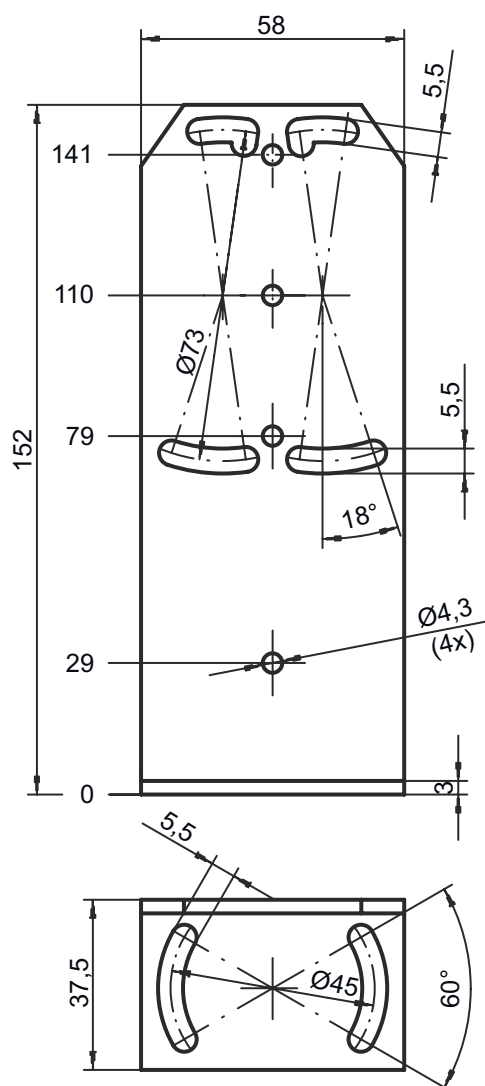

Dimensioned drawings

All dimensions in millimeters



Accessories

Standard reflectors

	Part no.	Designation	Article	Description
	50022816	TKS 100X100	Reflector	Design: Rectangular Reflective surface: 96 mm x 96 mm Triple reflector size: 4 mm Material: Plastic Base material: Plastic Chemical designation of the material: PMMA8N Fastening: Through-hole mounting, Adhesive
	50022815	TKS 50X100	Reflector	Design: Rectangular Reflective surface: 46 mm x 96 mm Triple reflector size: 4 mm Material: Plastic Base material: Plastic Chemical designation of the material: PMMA8N Fastening: Through-hole mounting, Adhesive

Note



A list with all available accessories can be found on the Leuze website in the Download tab of the article detailed page.