

Floor standing enclosures Combinable and compact version

MOUNTING INSTRUCTIONS

7697-0262-01 REV.14

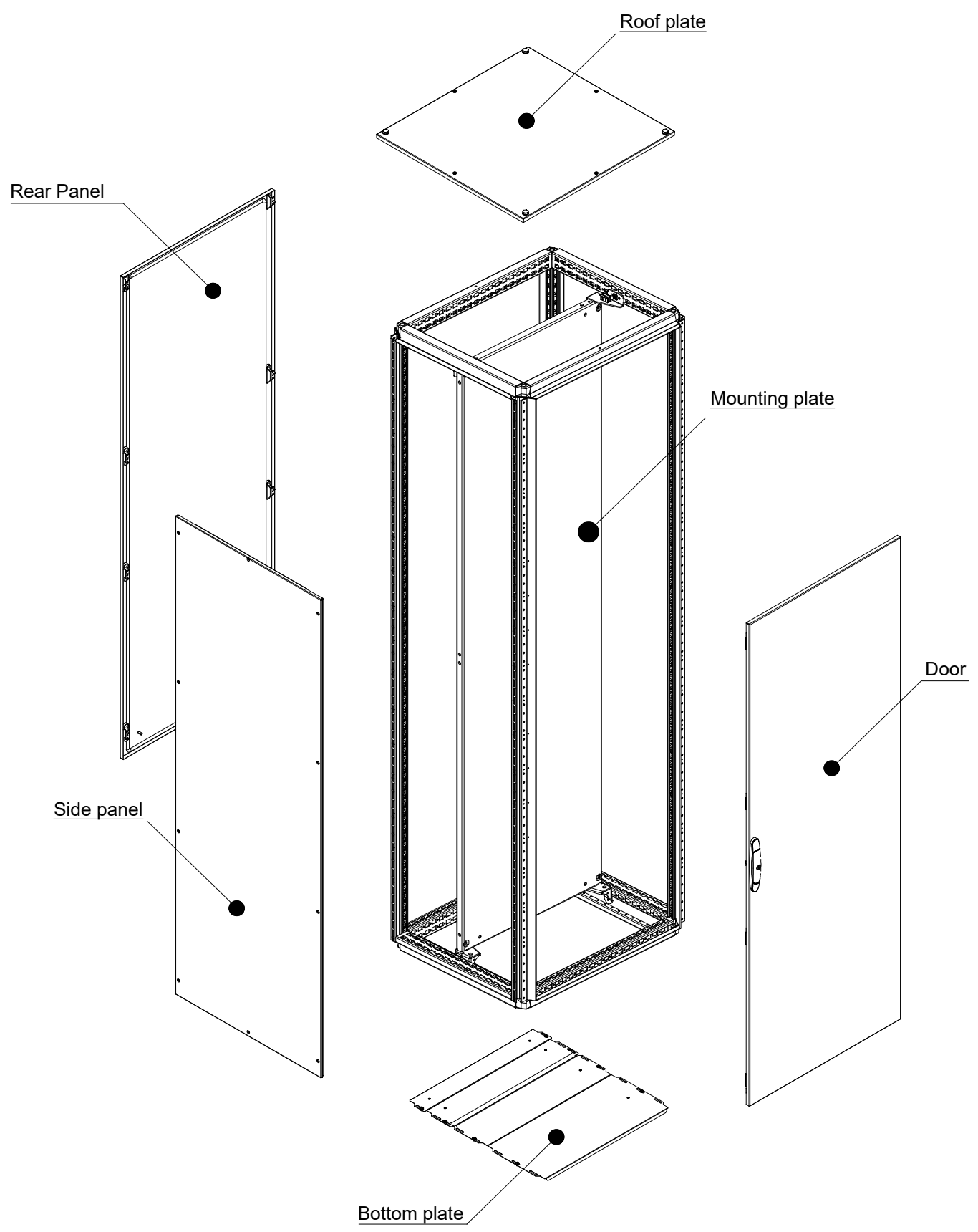



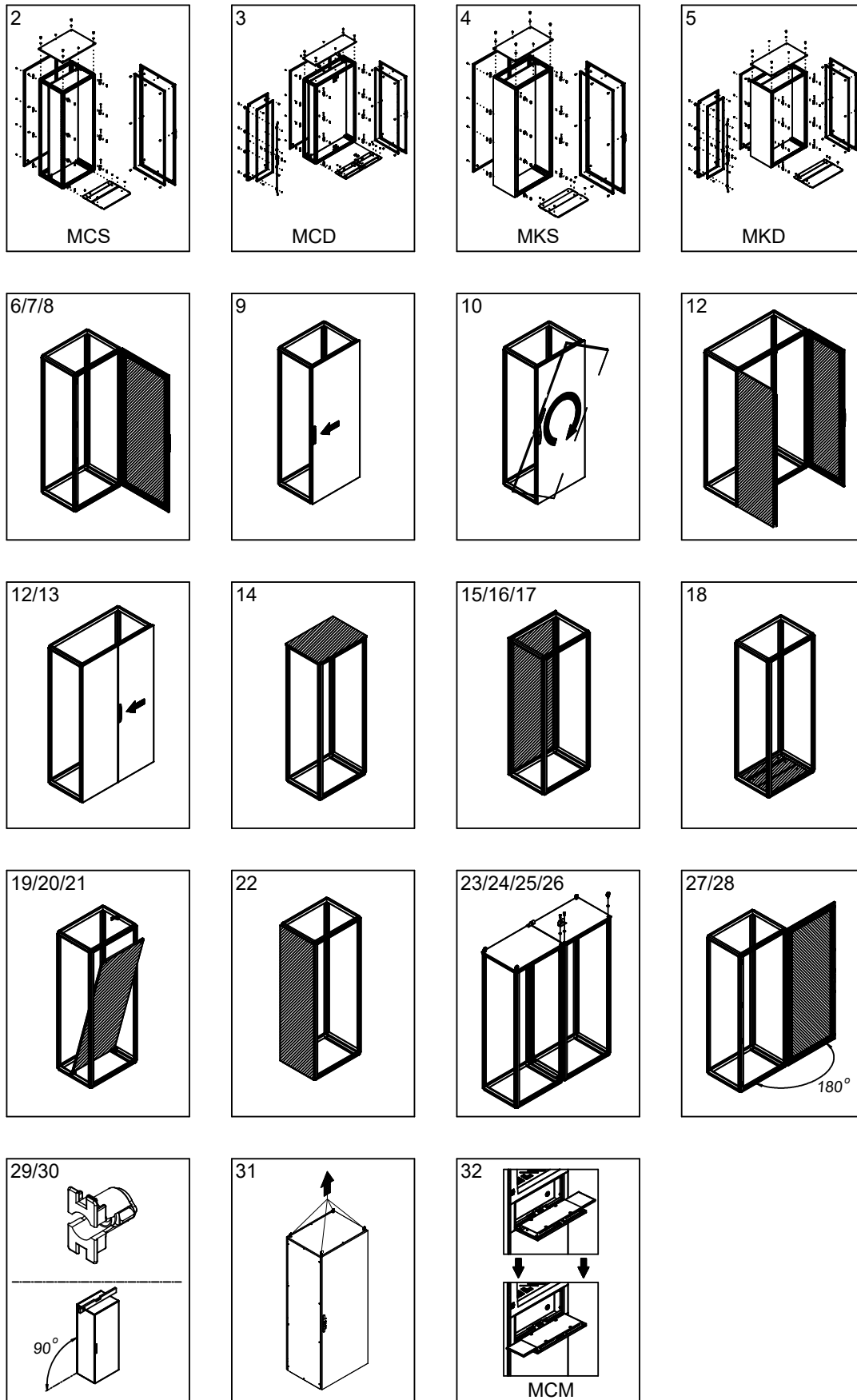

WARNING: When mounting on or over a combustible surface, a floor plate of at least 1.43 mm galvanized or 1.6 mm uncoated steel extended at least 150 mm beyond the equipment on all sides must be installed.

WARNING: In order to maintain the environmental integrity of the enclosure, devices with the same environmental ratings shall be used to close openings in customized enclosure.

MCS

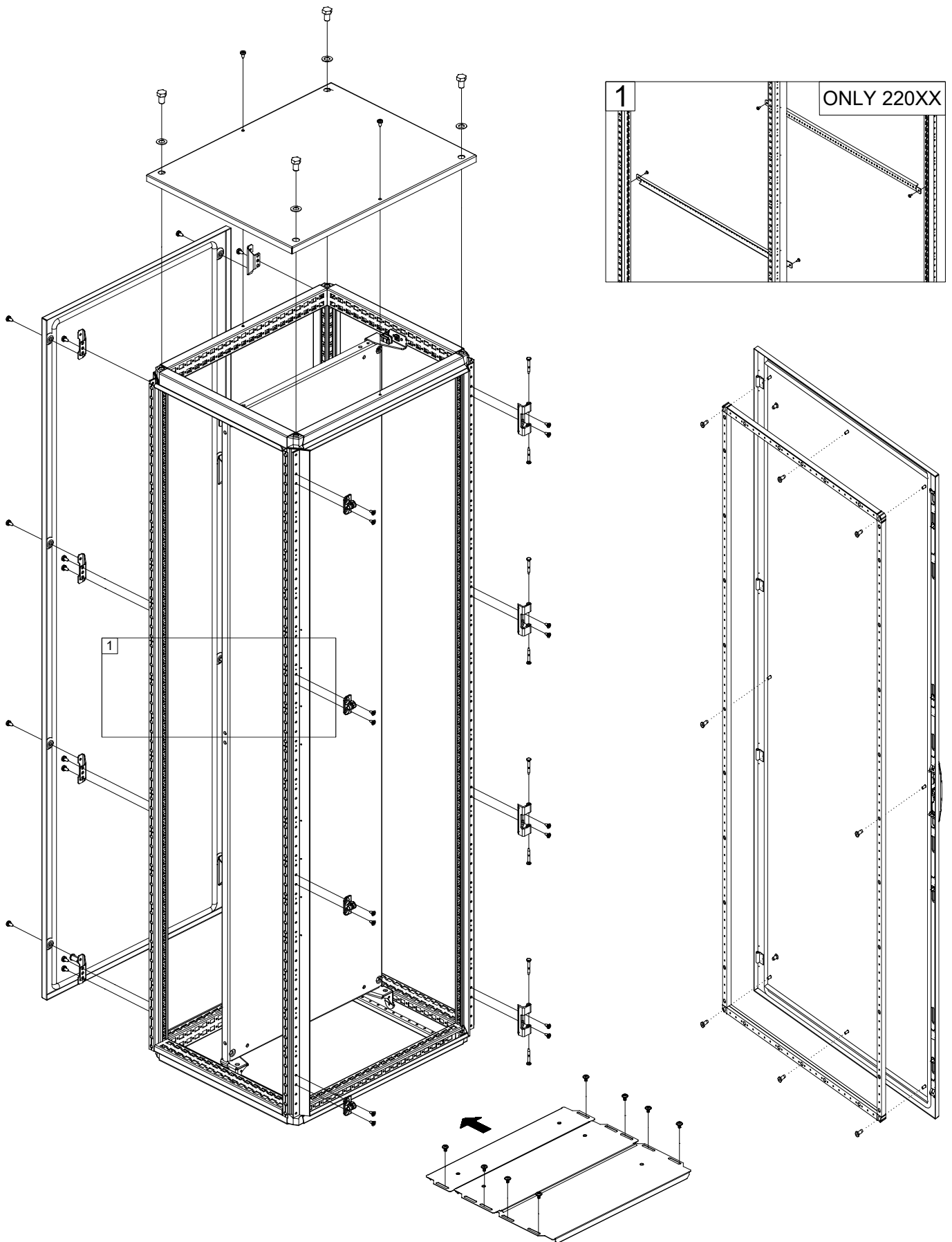

MCD

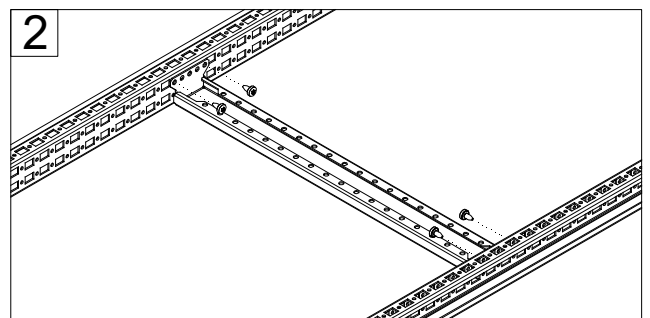
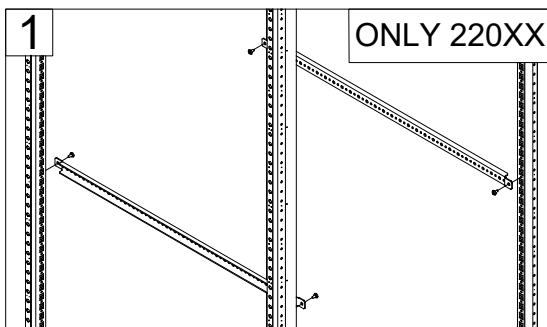
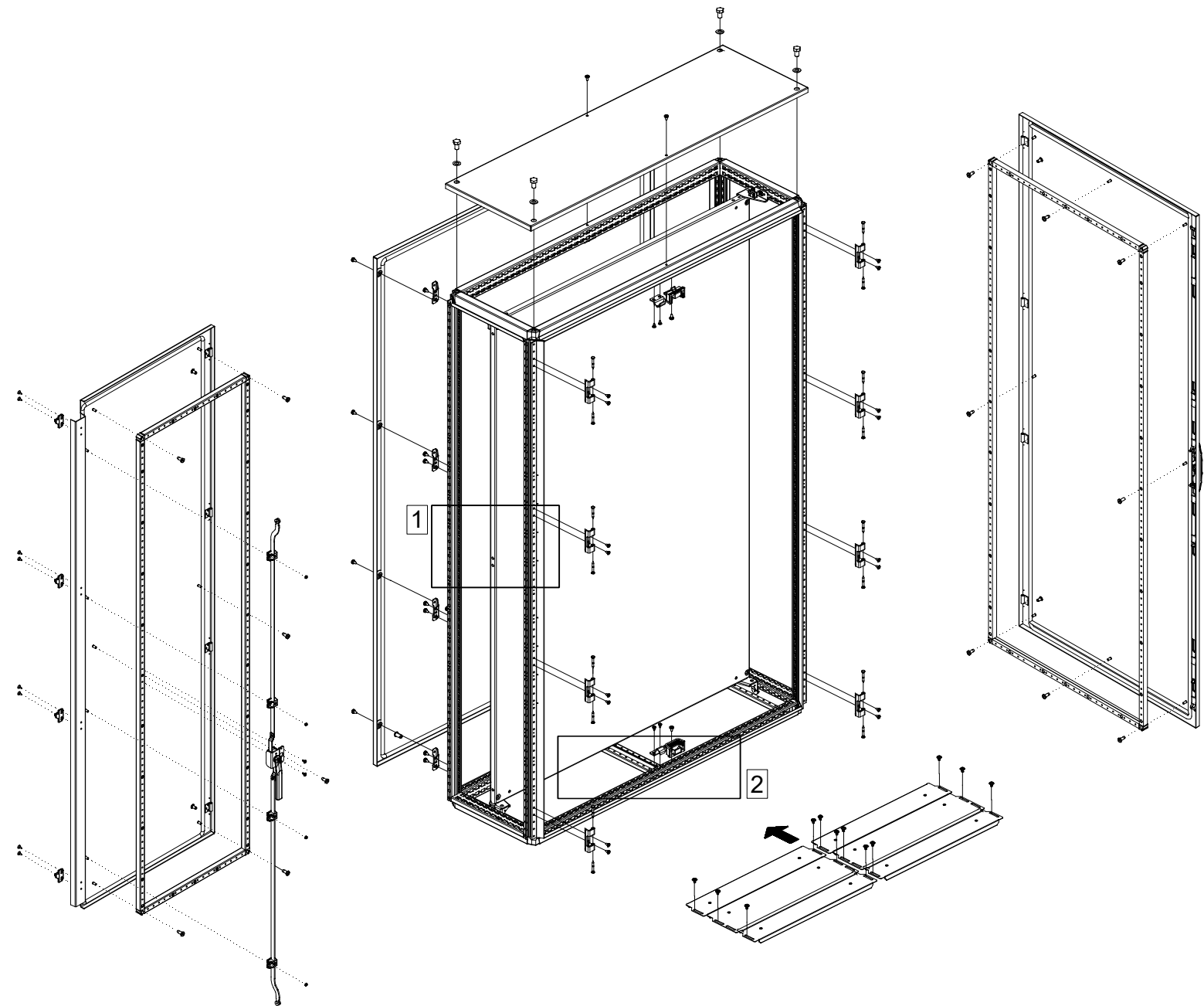

MKS

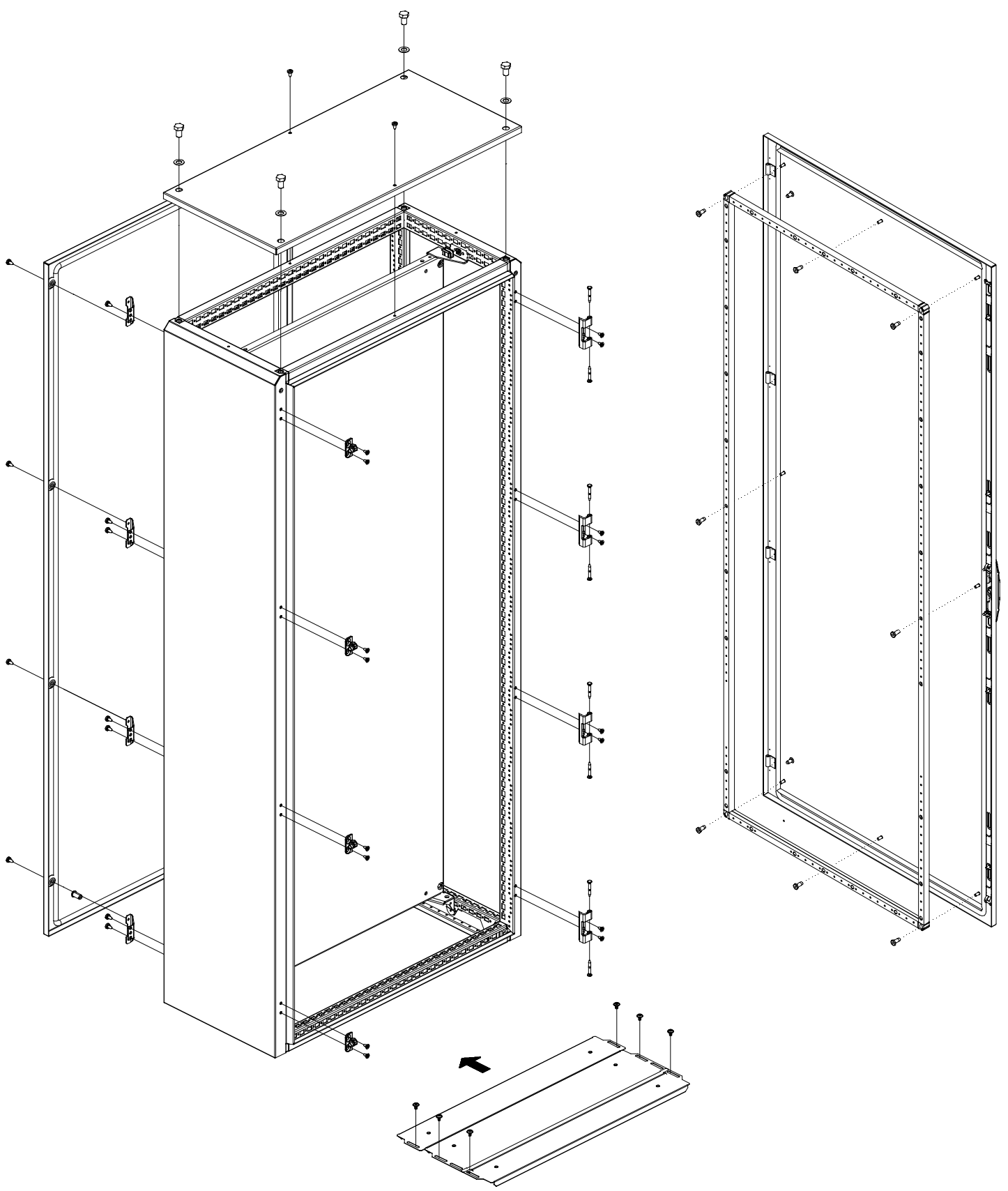

MKD

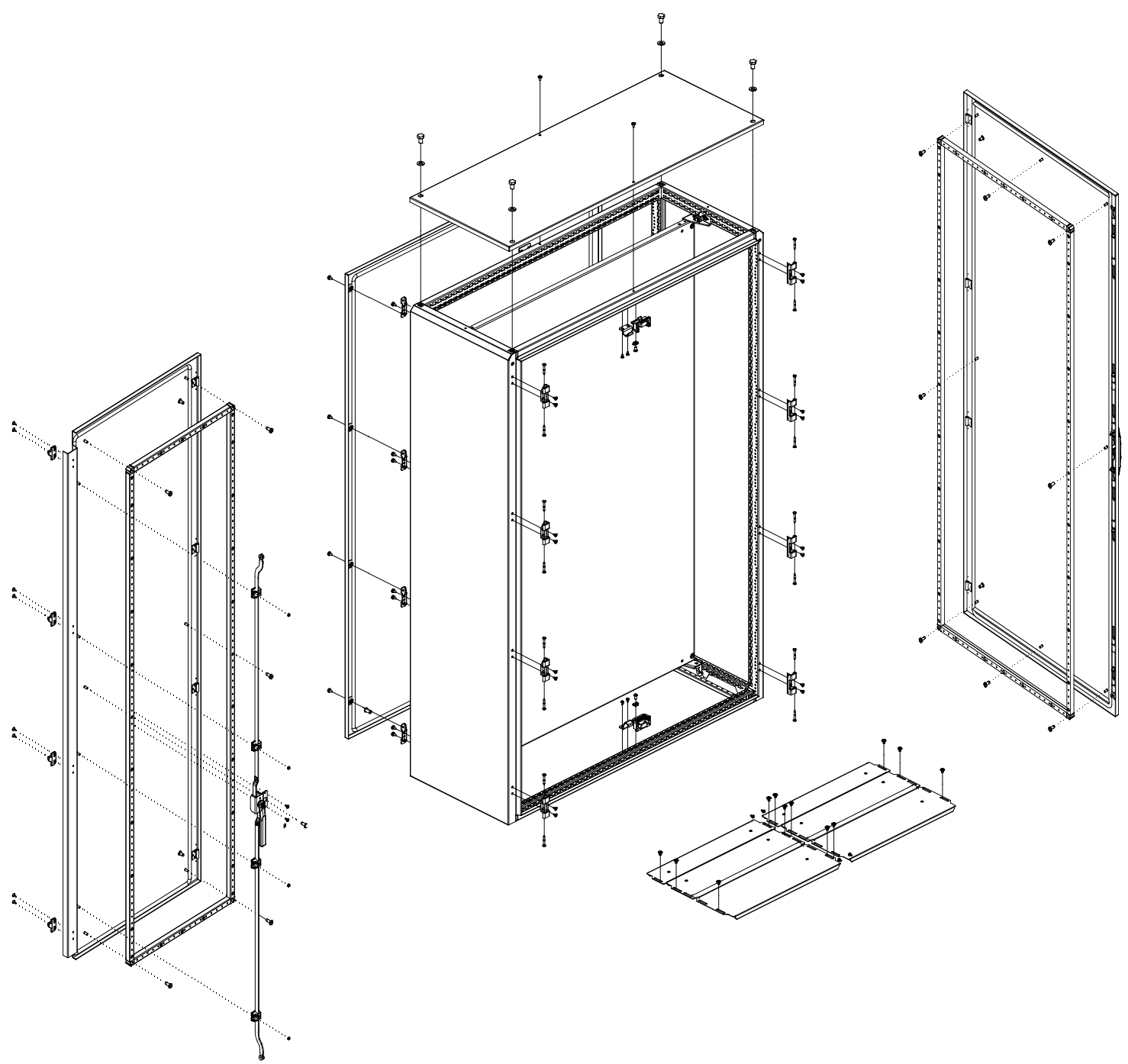

COMBINABLE ENCLOSURE



H	A
1100	175
1400	325
1600	425
1800	525
2000	625
2200	725

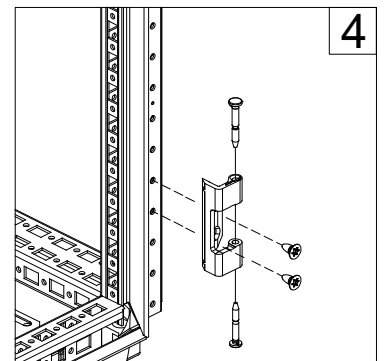
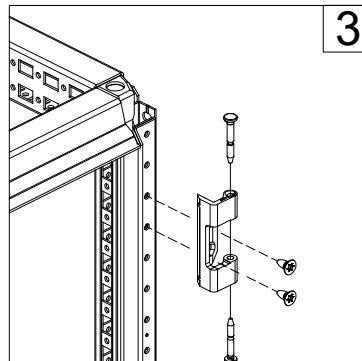
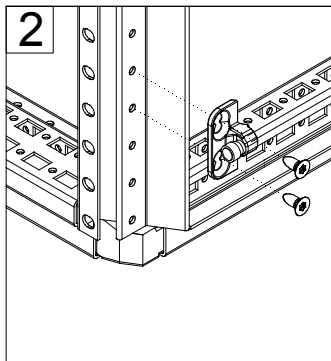
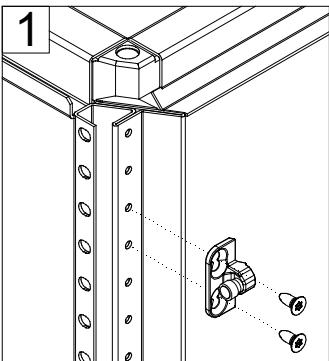
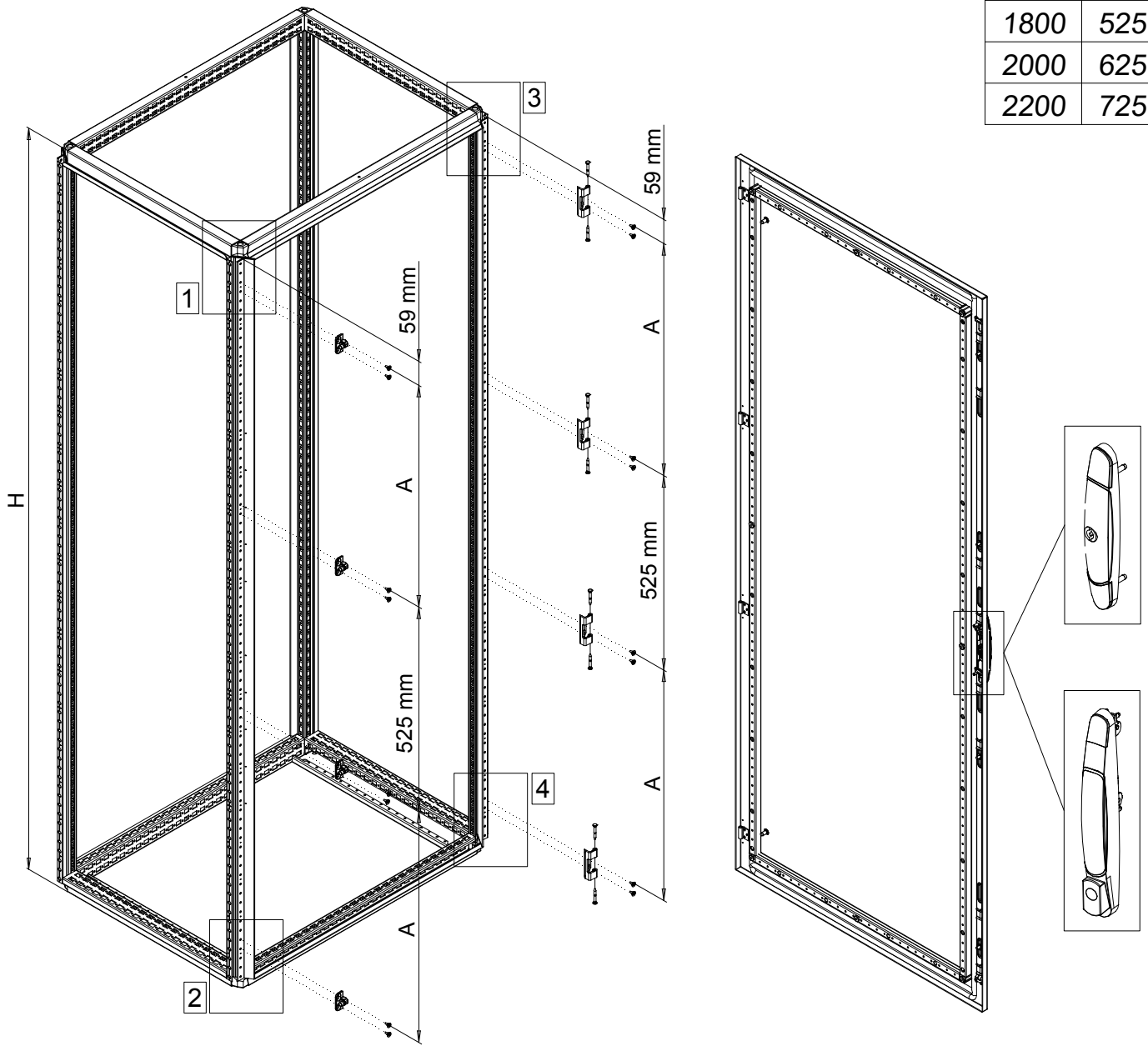



T30



SW13

COMPACT ENCLOSURE

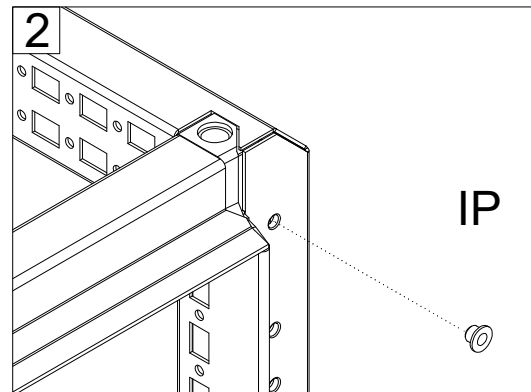
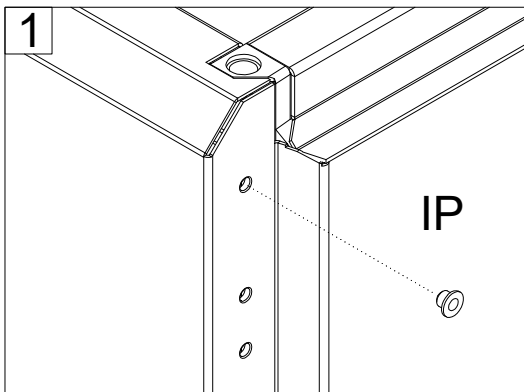
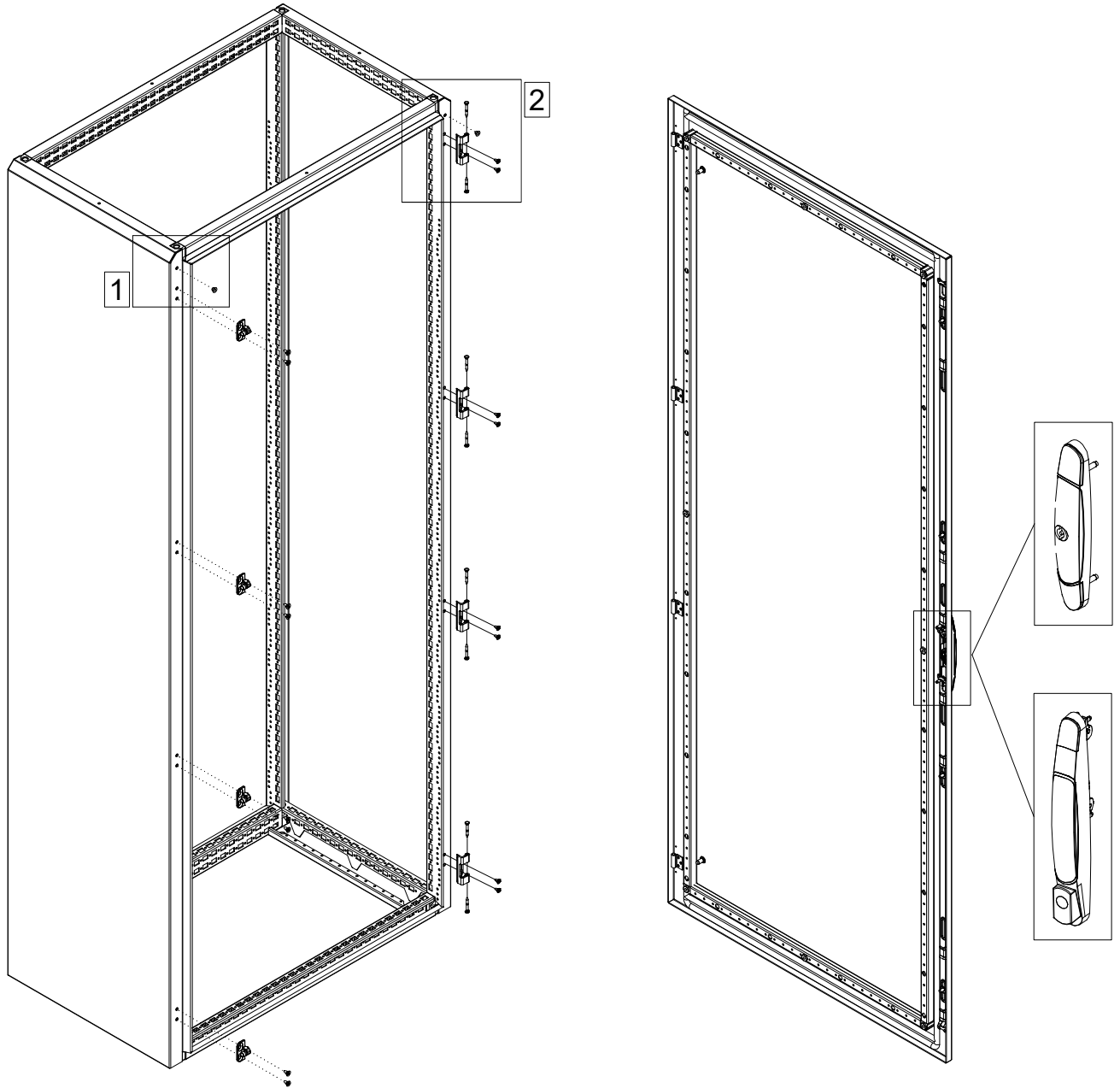



Ref.	Pic.	Qty.
A		2
B		4

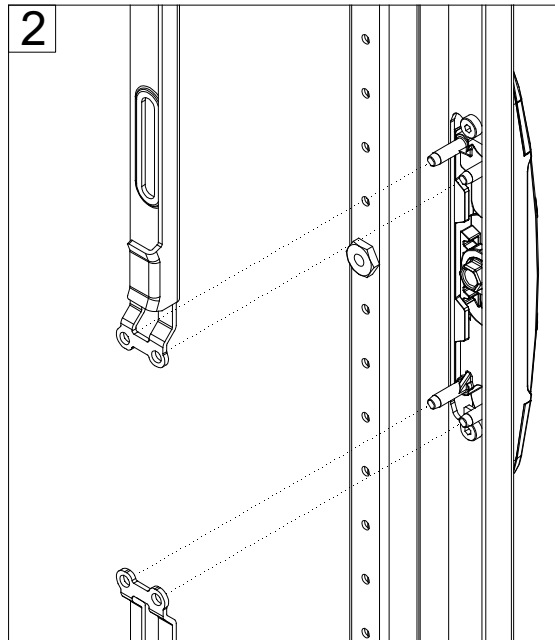
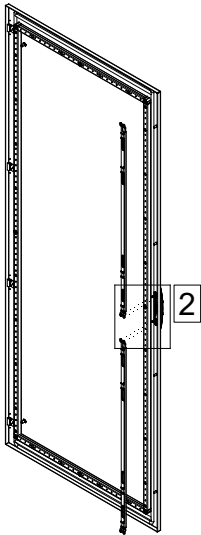
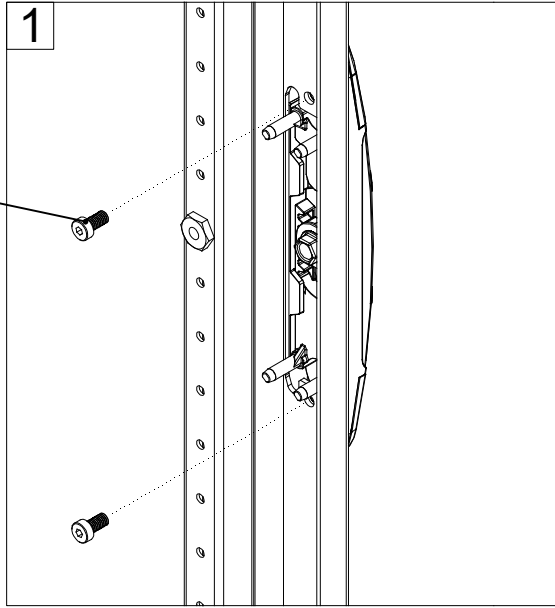
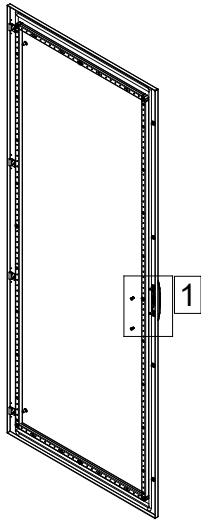

Metal Guider

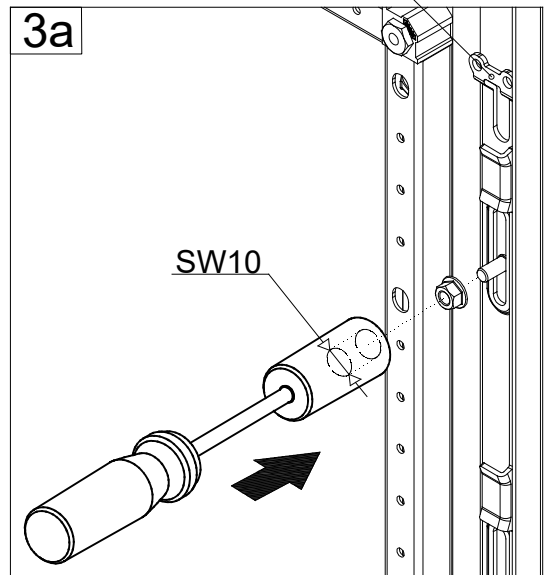
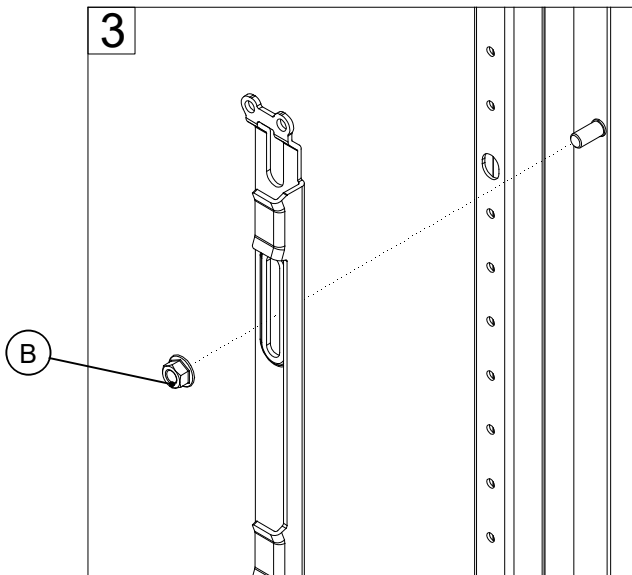
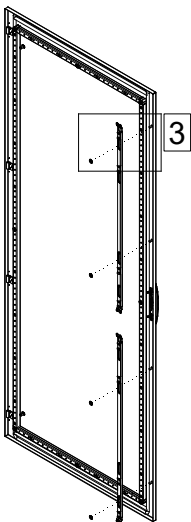



SW3

MOUNTING THE LIFT HANDLE

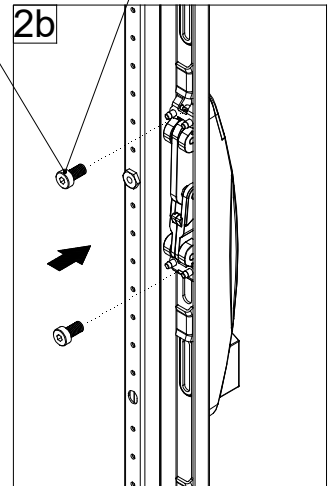
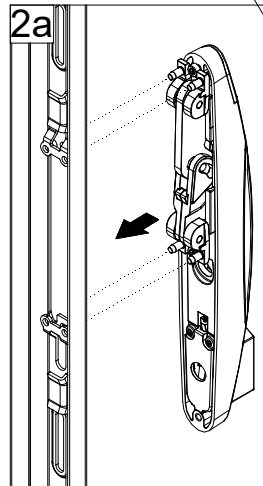
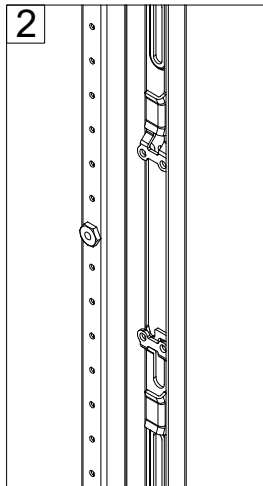
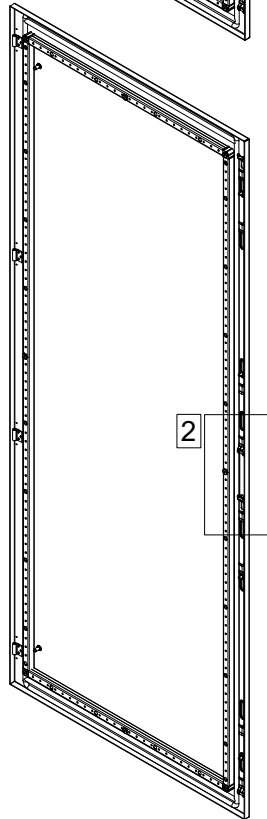
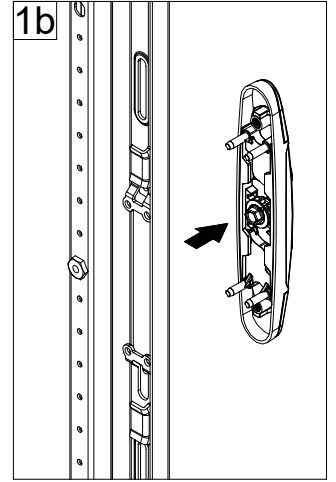
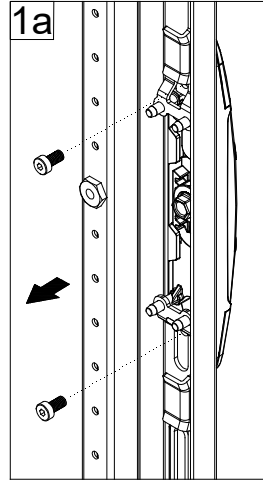
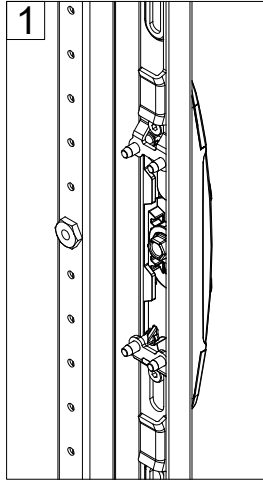
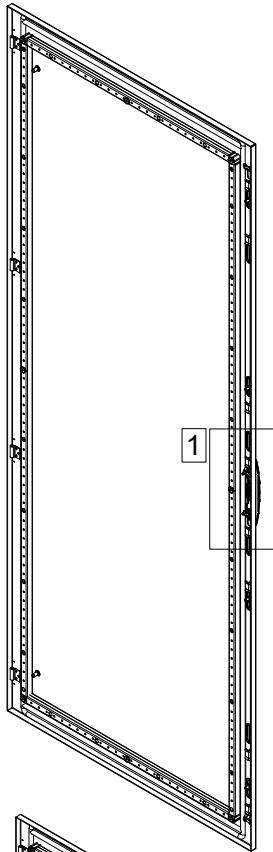

Torque
4-5.5 Nm

A



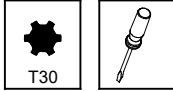

Standard Locking System

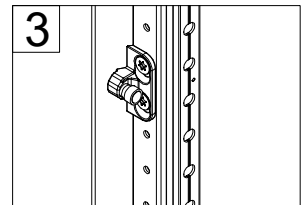
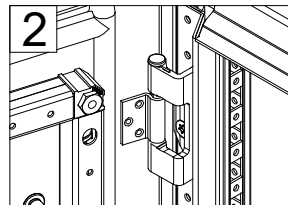
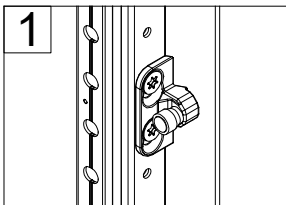
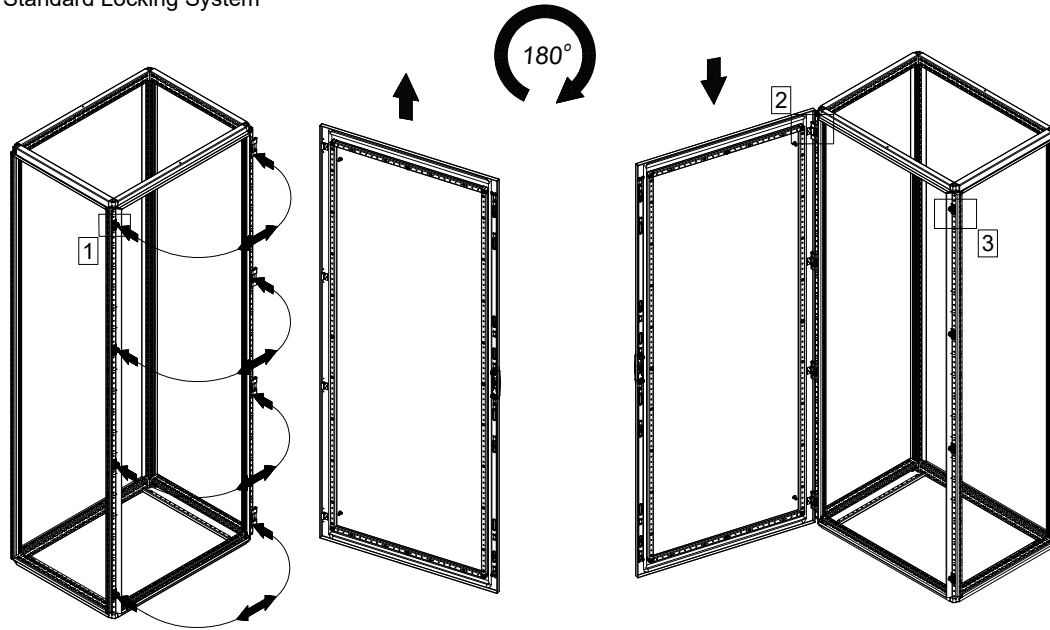

Lift Handle Locking System

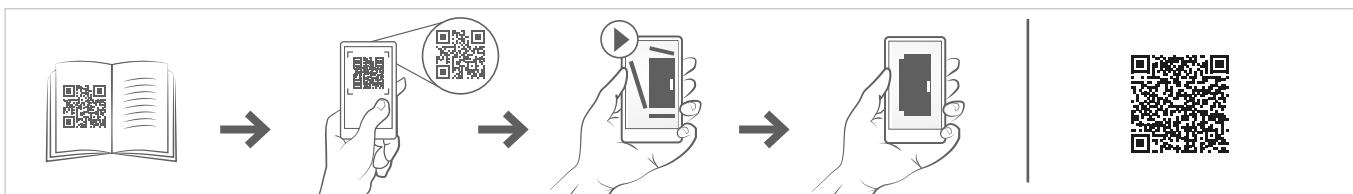
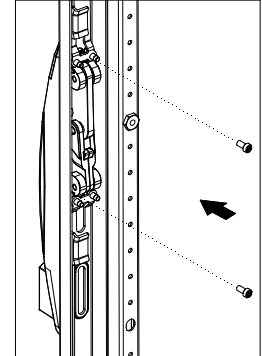
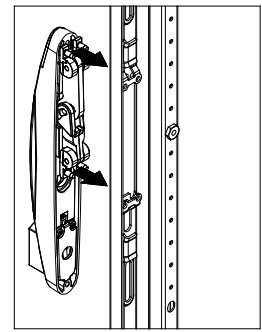
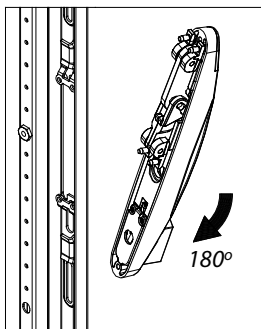
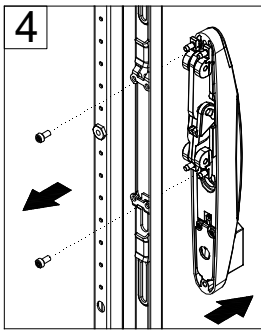
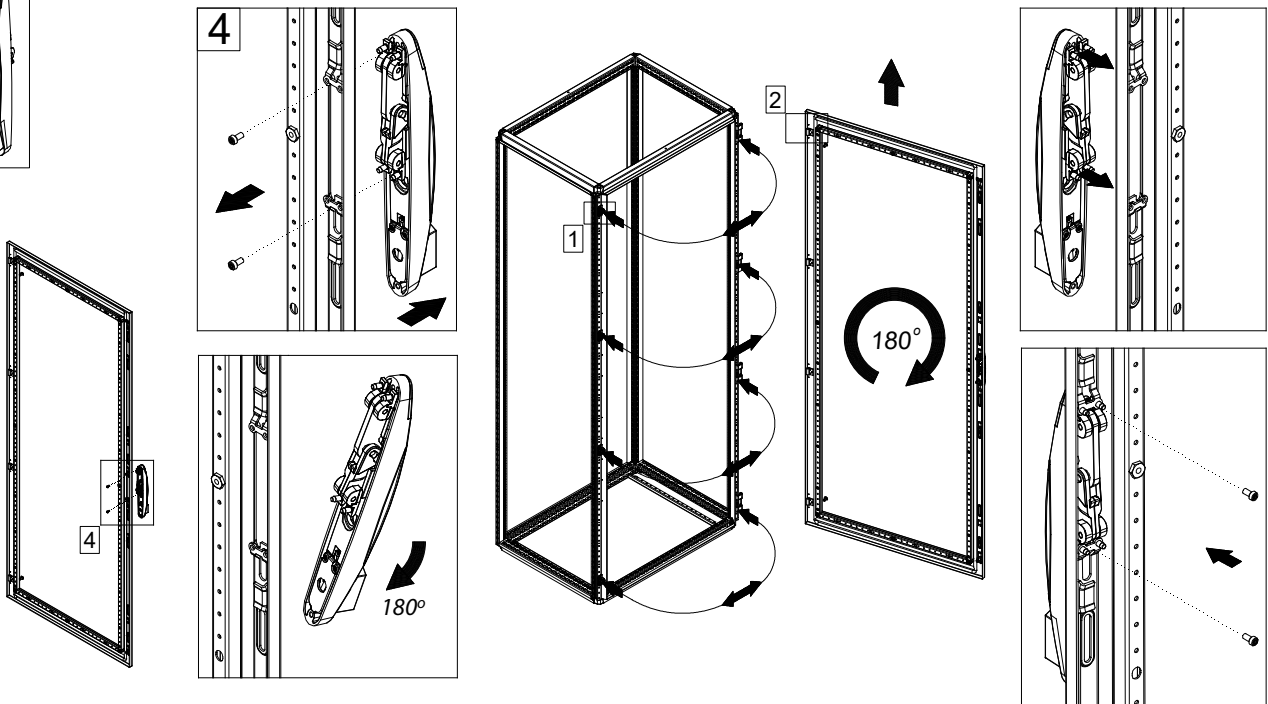
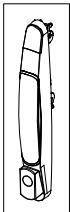

Standard Locking System

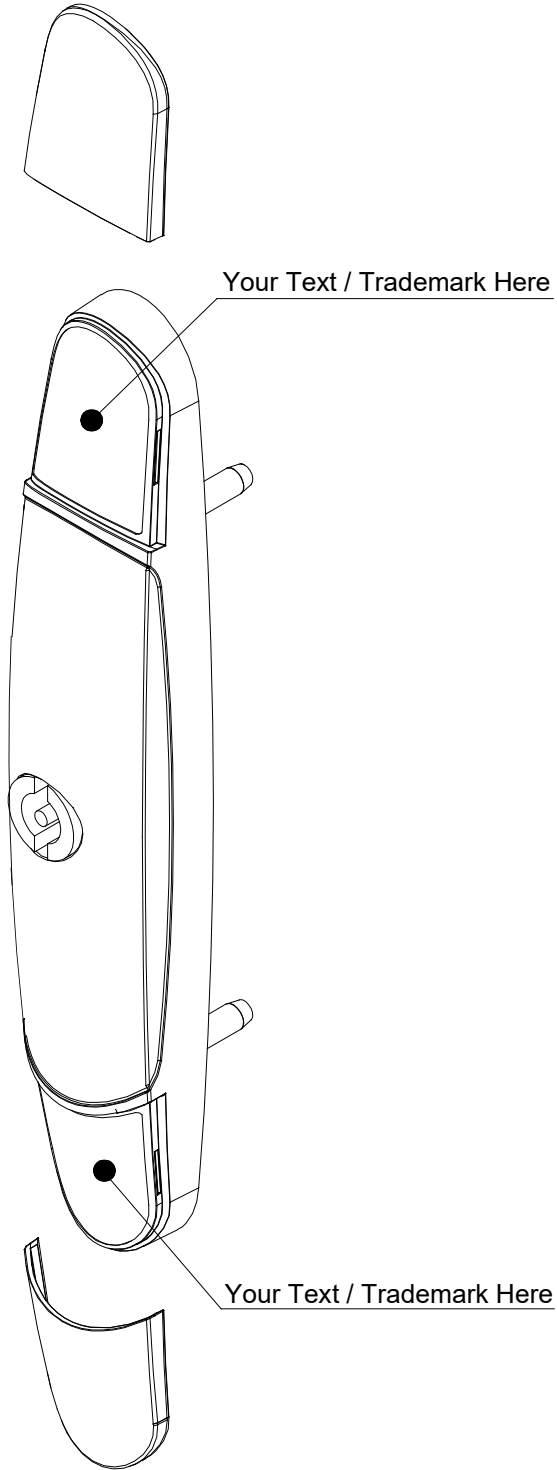

Lift Handle Locking System

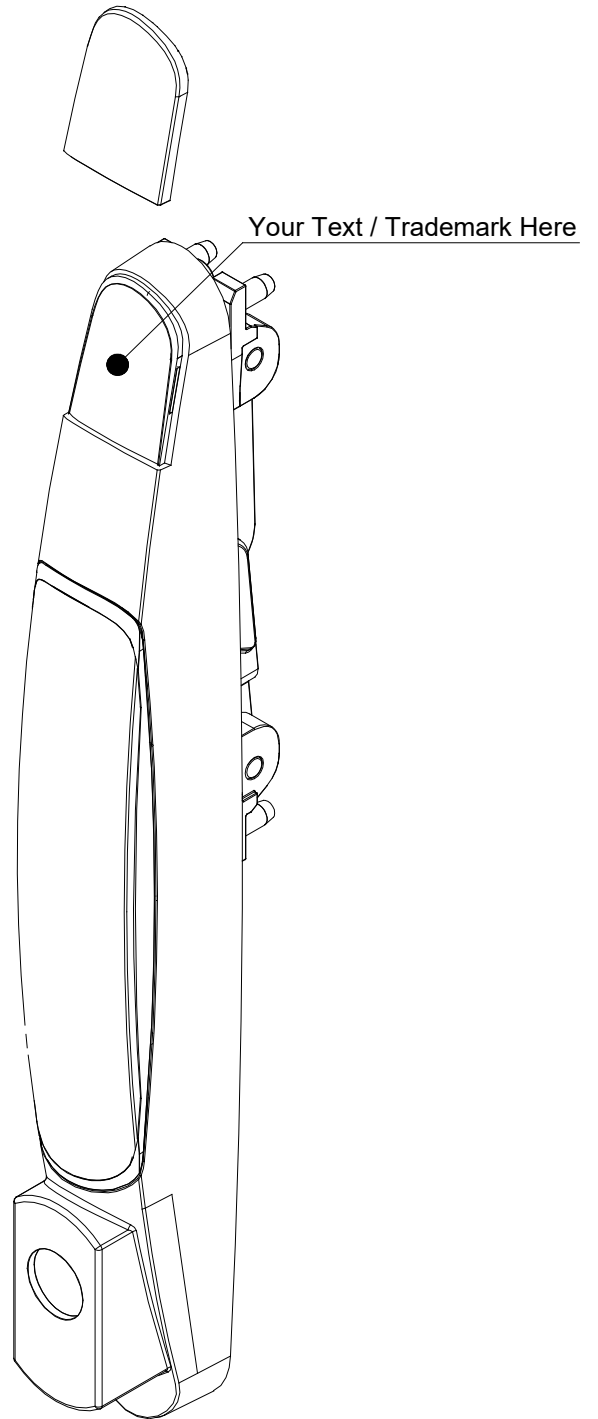



Ref.	Pic.	
A		8
B		2
C		2
D		16
E		2
F		2

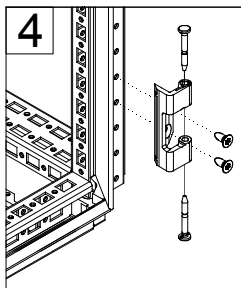
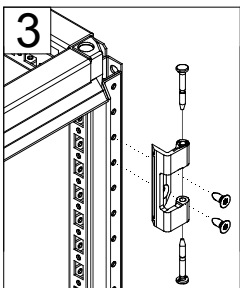
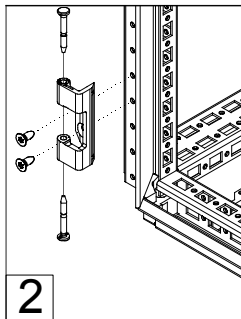
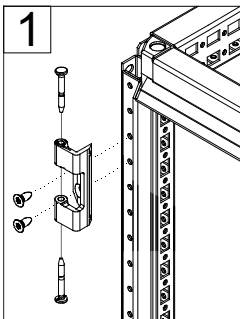
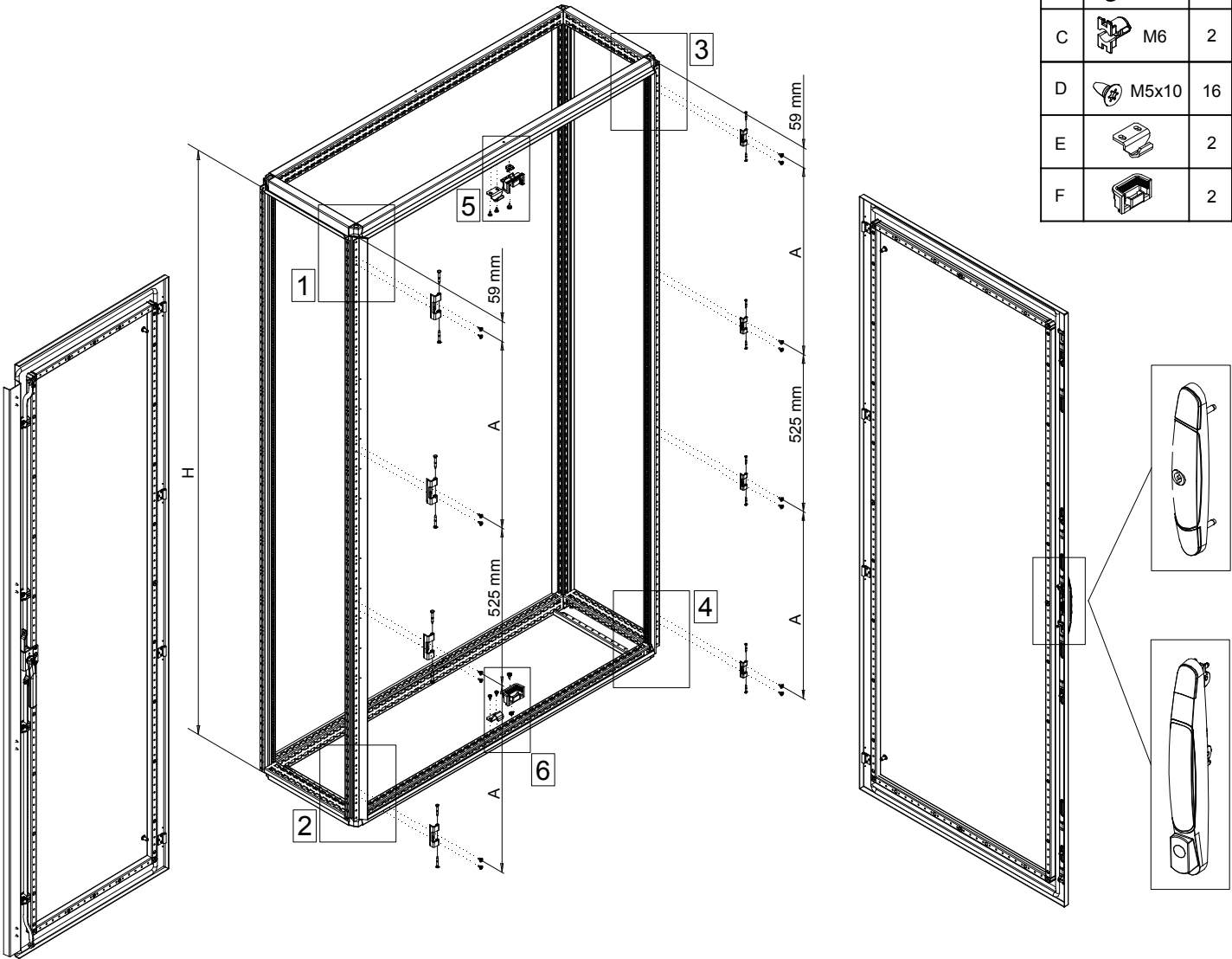

H	A
1100	175
1400	325
1600	425
1800	525
2000	625
2200	725

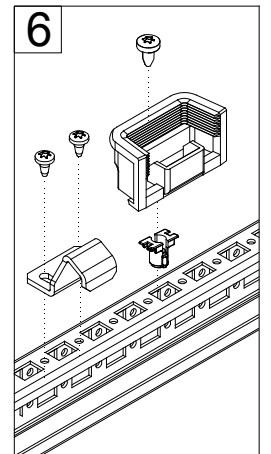
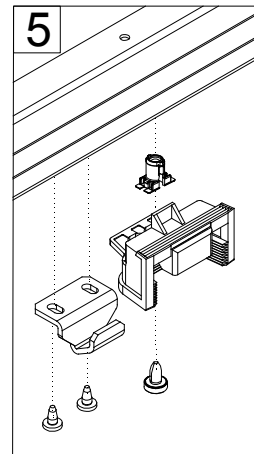



MOUNTING LSEL

Ref.	Pic.	Qty.
A		6
B		4
C		8
D		1
E		1

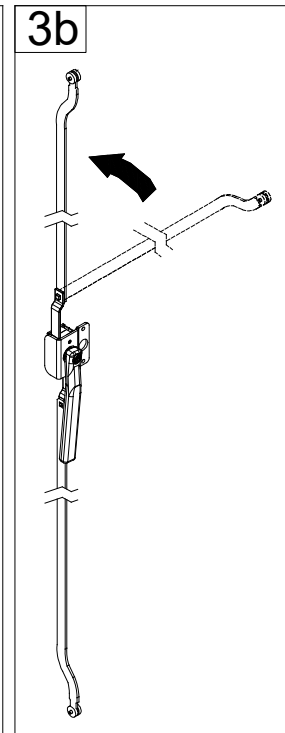
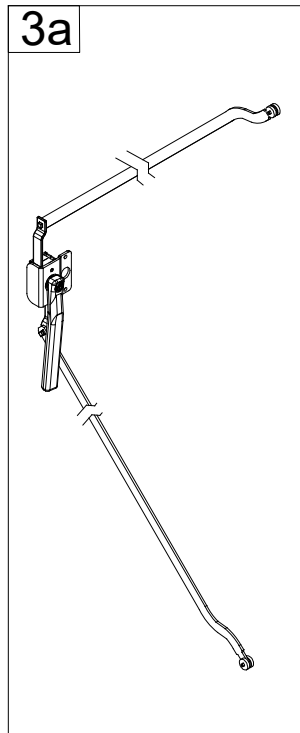
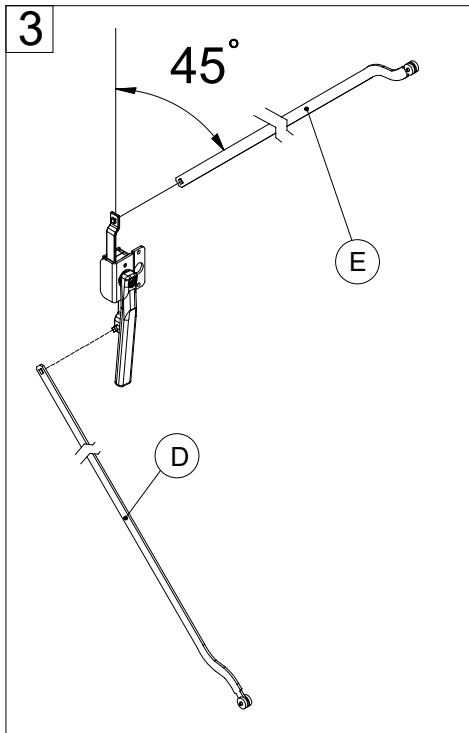
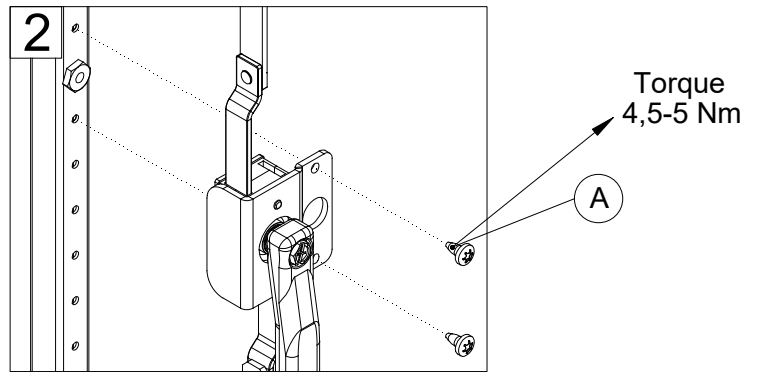
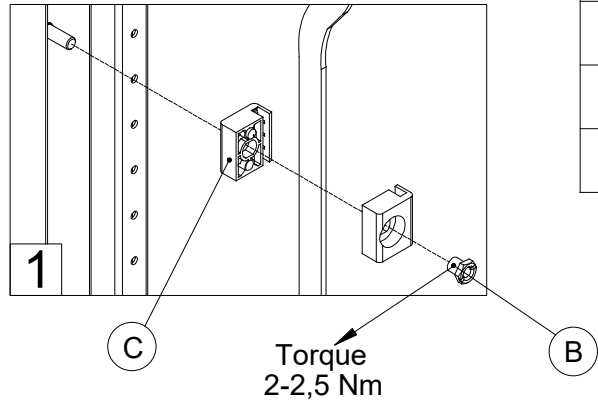
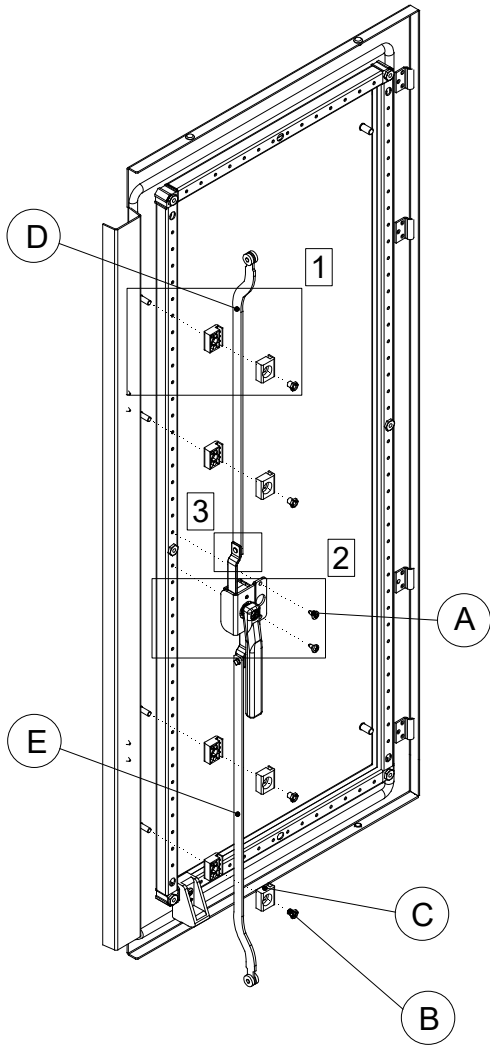



Ref.	Pic.	D (mm)	<800	≥800
A	M6x12		2	4
B	M12x20		4	4
C	M12		4	4

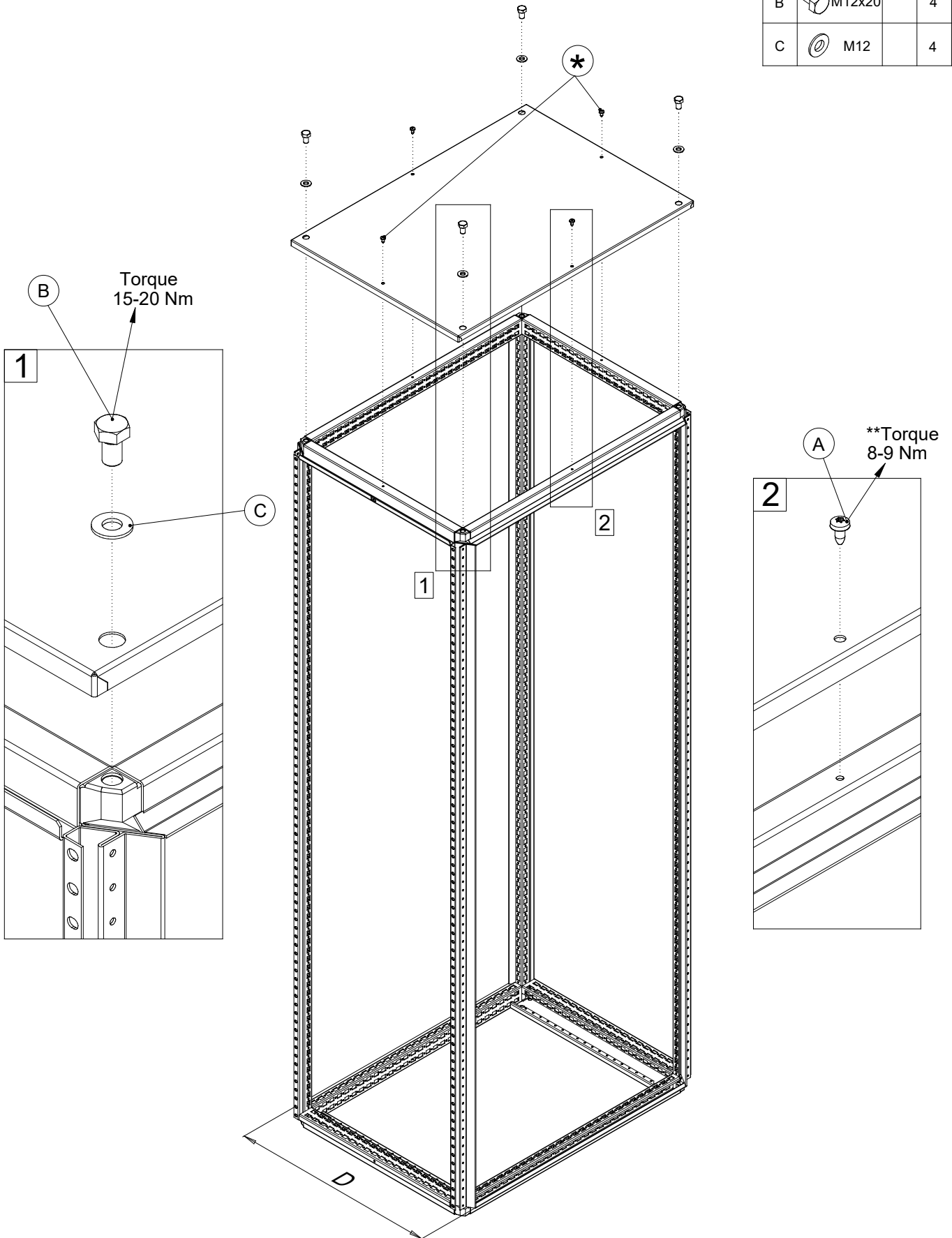

* - Used on enclosures 800mm deep and above.

** - Torque value for first tightening. For following tightening, torque value recommended is 4-5 Nm.

MCS BACK PANEL



Ref.	Pic.	W (mm)	<1000	≥1000
A		M5x10	-	2
B		M6x12	16	18

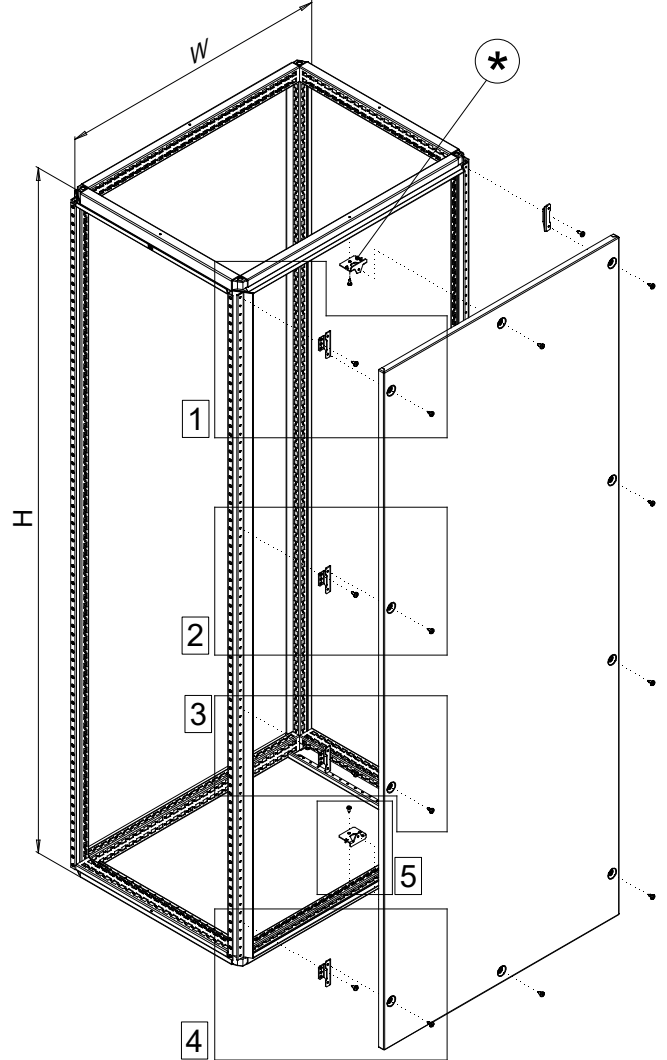
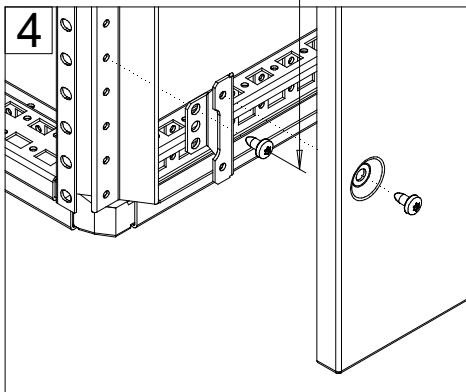
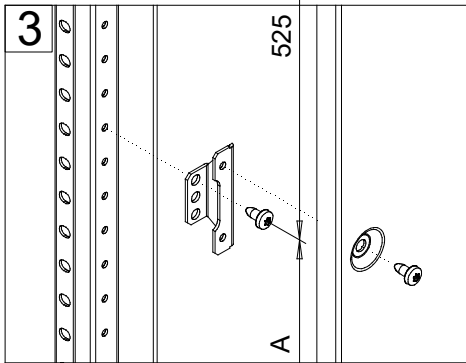
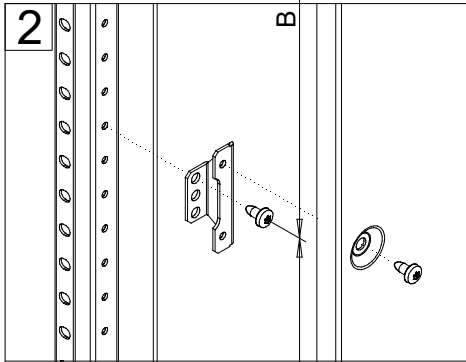
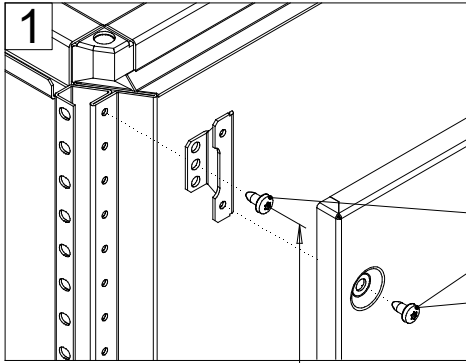

H	A	B
1100	-	350
1400	325	375
1600	425	475
1800	525	575
2000	625	675
2200	725	775

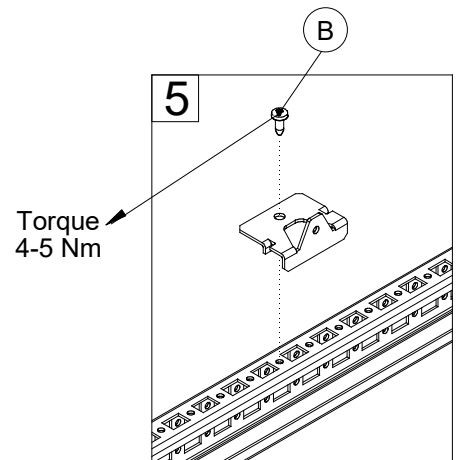

* - Used on enclosures 1000mm wide and above.

MKS BACK PANEL

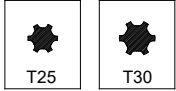

Ref.	Pic.	W (mm)	<1000	≥1000
A	M5x10		-	2
B	M6x12	22	24	
C			4	4

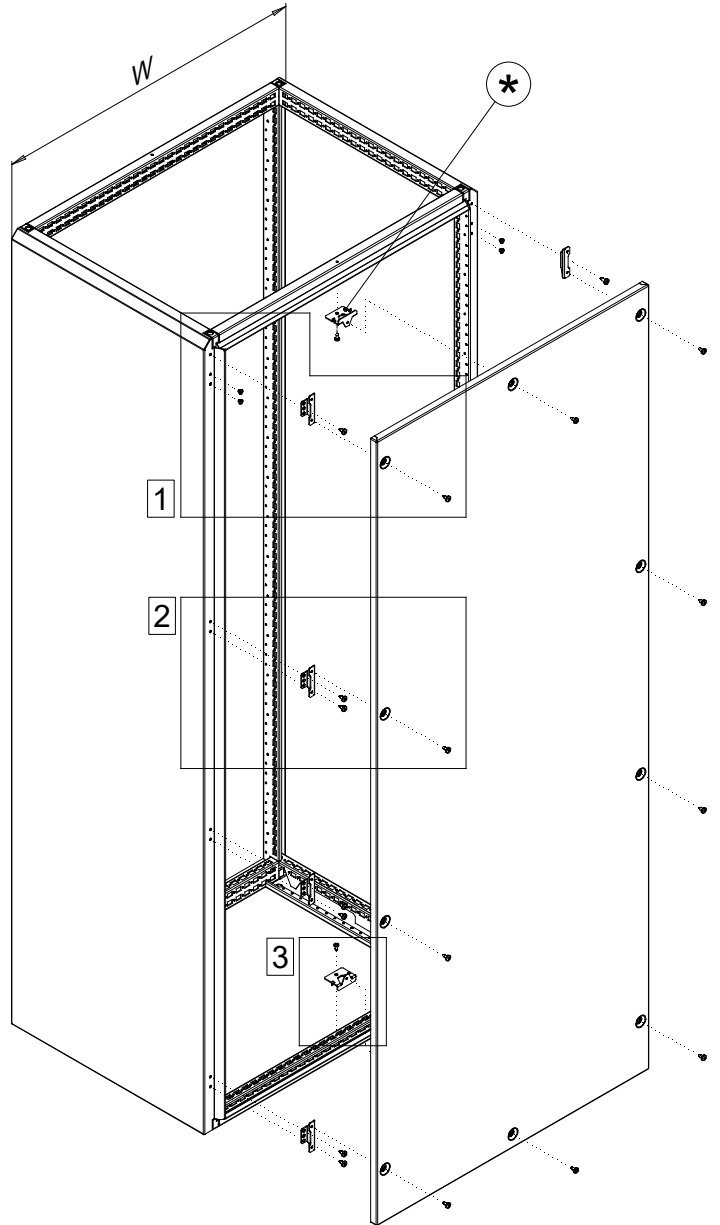
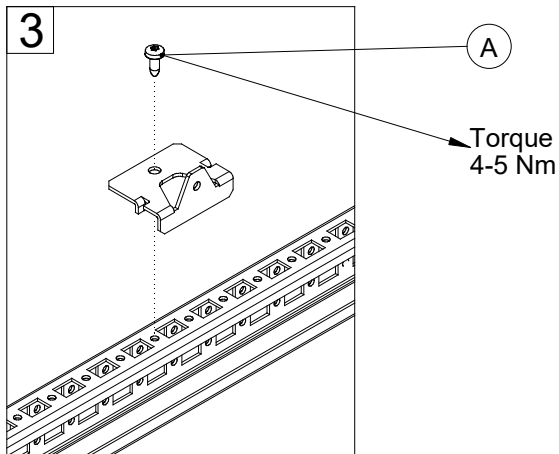
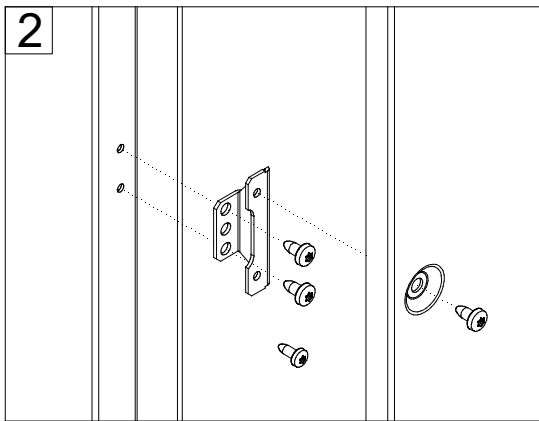
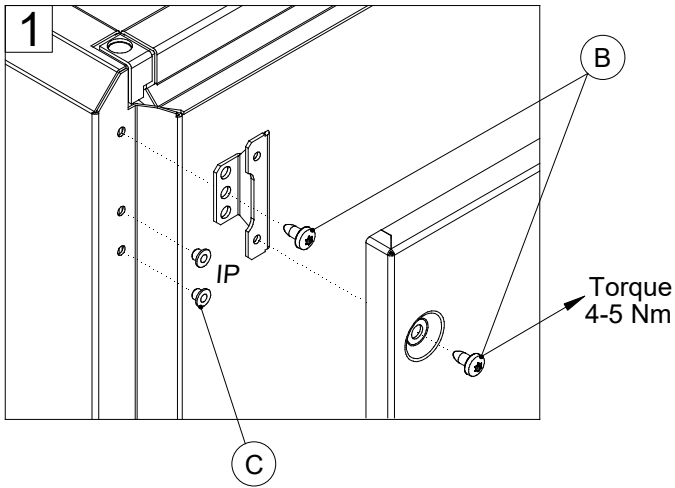

* - Used on enclosures 1000mm and 1200mm wide.



MKD BACK PANELS

Ref.	Pic.	Qty.
A		4
B		28
C		4

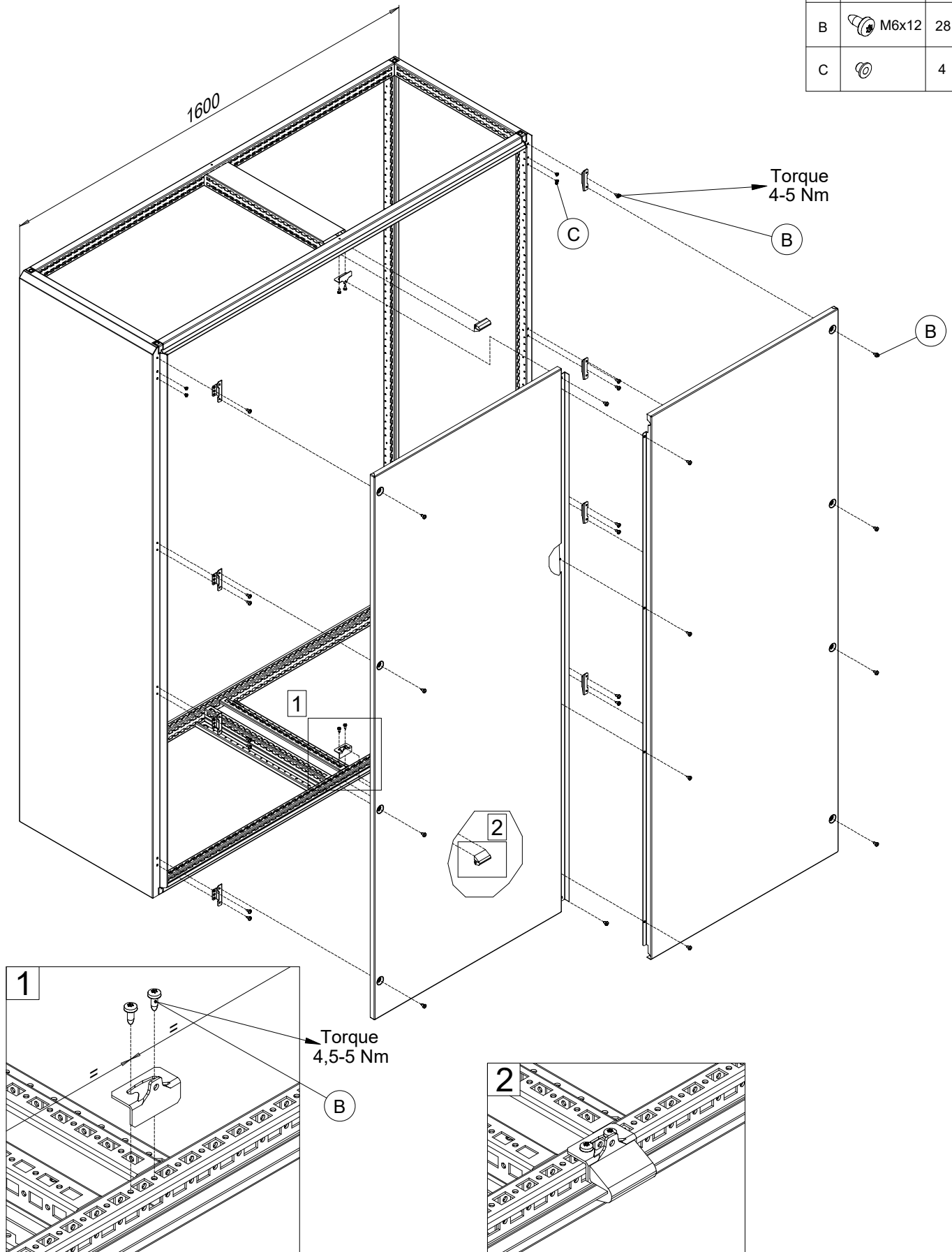



T25

BOTTOM PLATE

Ref.	Pic.	Qty.
A	St. 5.5x10	6/8/12/16
B	M5x10	4
C	Washer	5/7/10/14

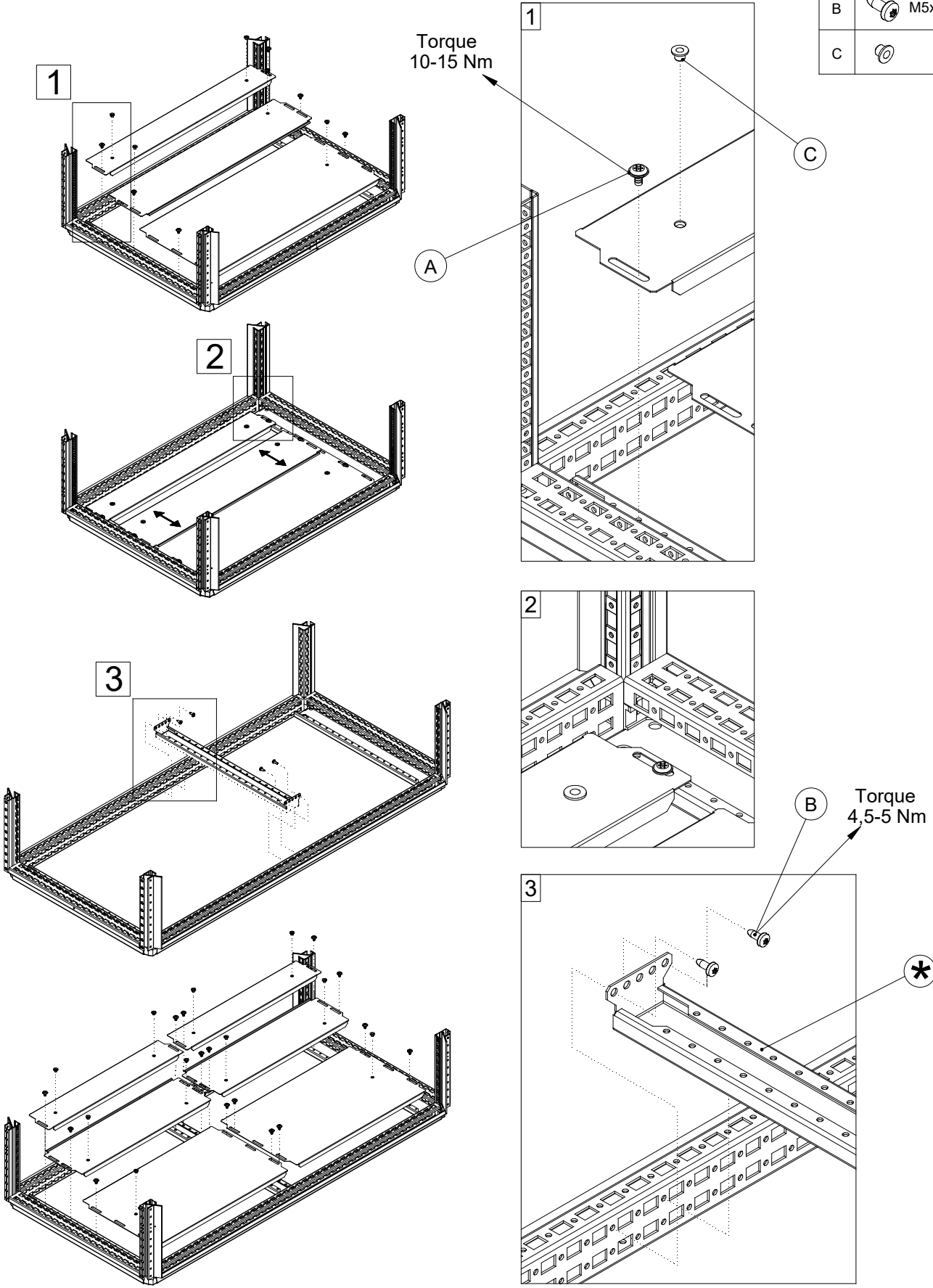

* - Used only on 1200mm wide enclosures.



MOUNTING PLATE

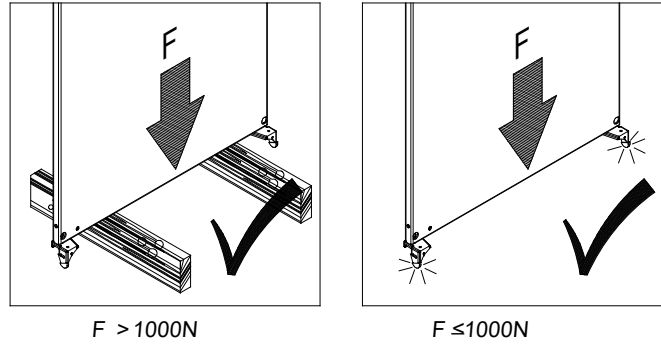

Ref.	Pic.	Qty.
A	M8x16	2
B	M8x16	2
C		2
D	Bottom right	1
E	Bottom left	1
F	Top right	1
G	Top left	1

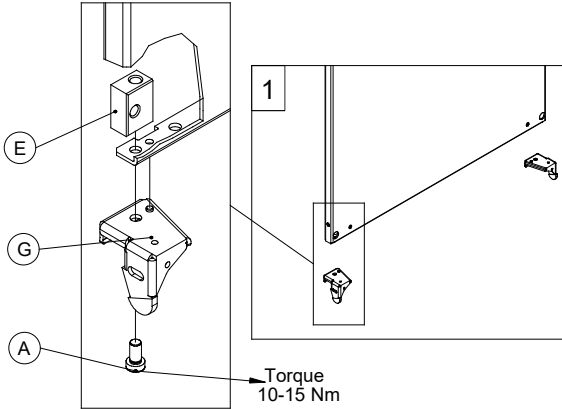



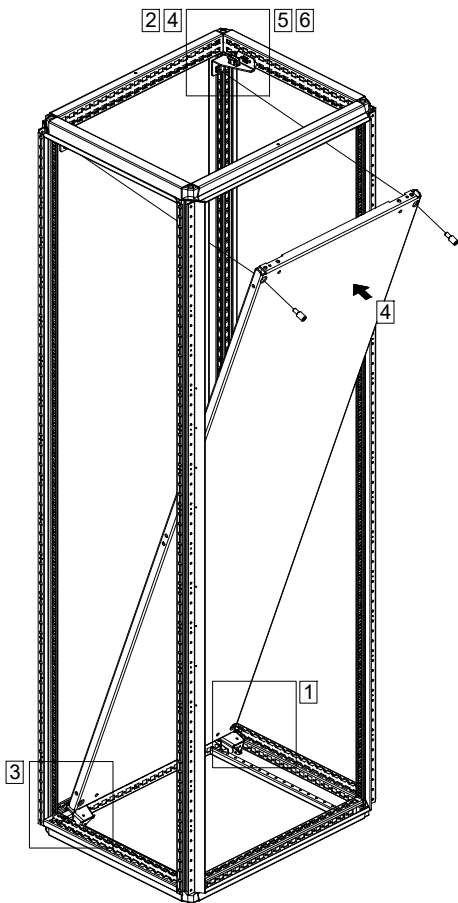
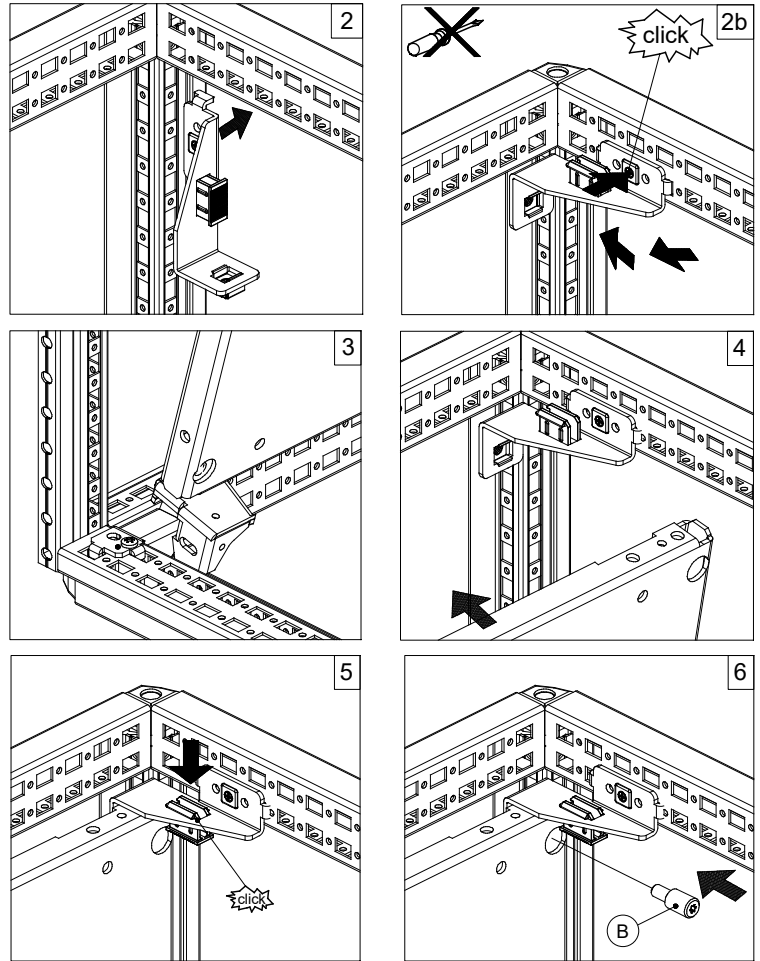



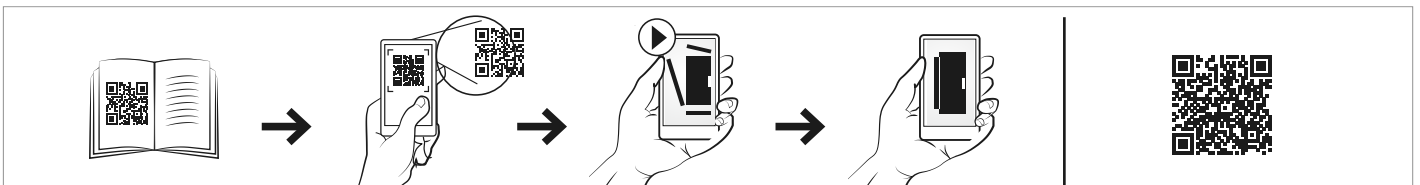
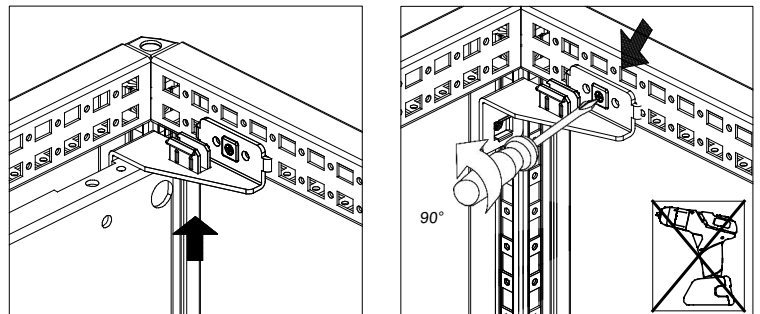

MOUNTING



UNMOUNTING



MOUNTING PLATE 1600 WIDE

Ref.	Pic.	Qty.
A	 M8x16	2
B	 M8x16	2
C		2
D	 Bottom right	1
E	 Bottom left	1
F	 Top right	3
G	 Top left	3
H	 M8x40	4

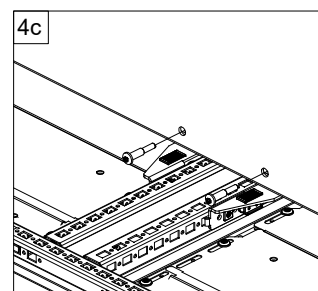
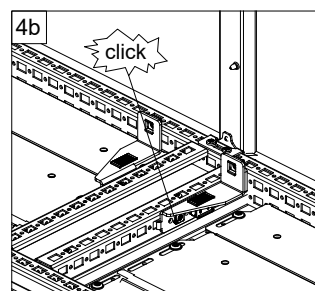
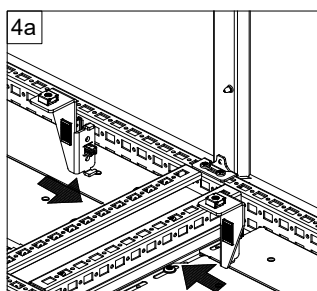
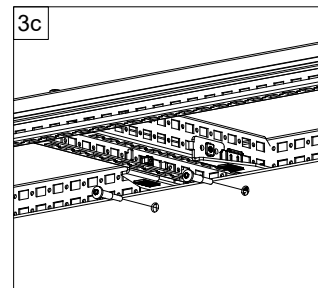
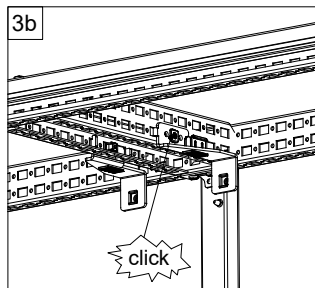
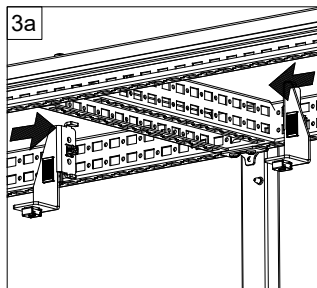
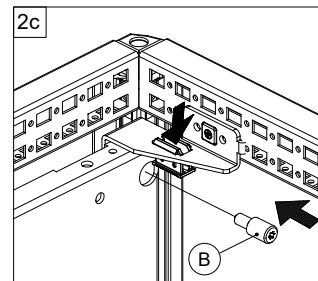
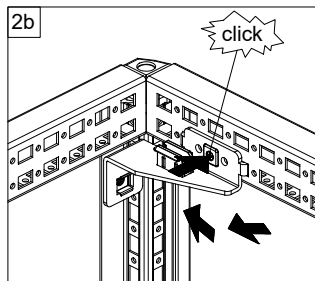
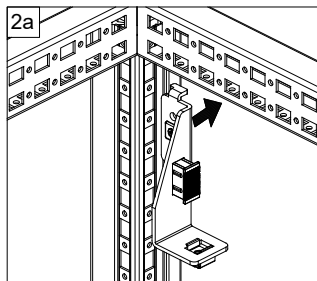
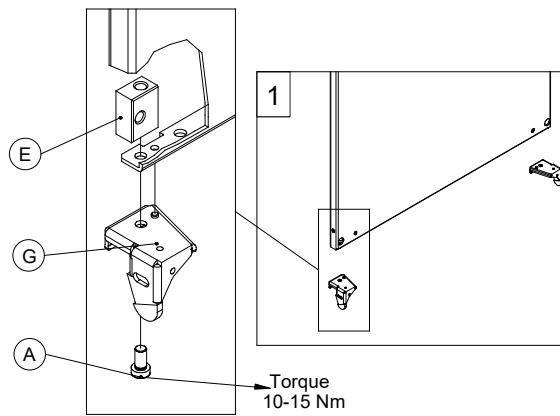
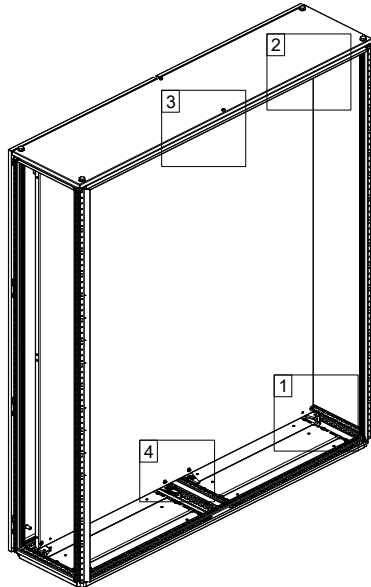
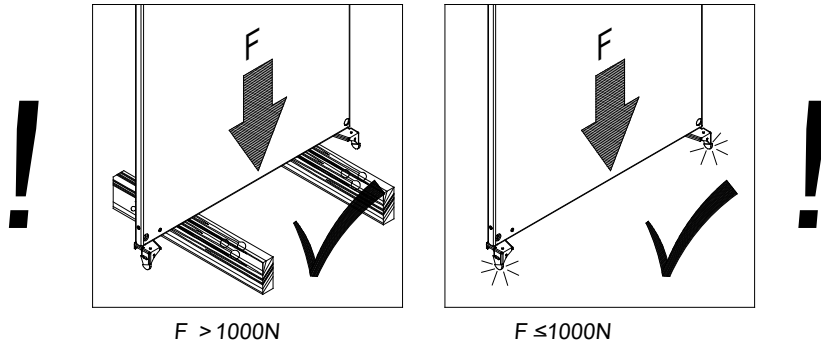

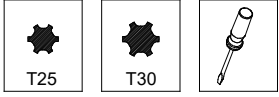

MPD02

Ref.	Pic.	Qty.
A	M5X12	2
B	Bottom left	1
C	Bottom right	1

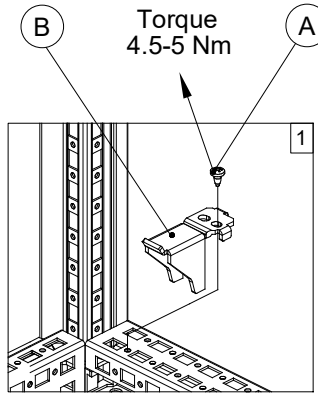
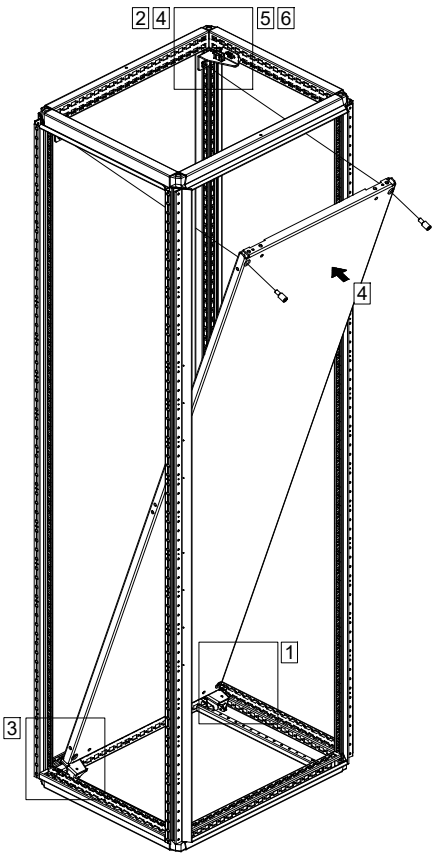

MOUNTING

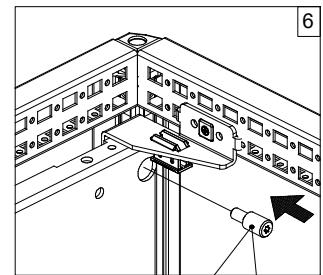
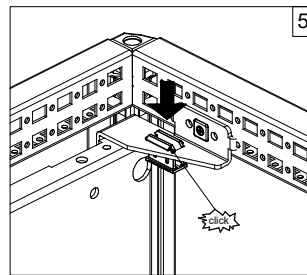
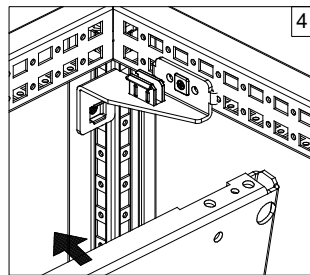
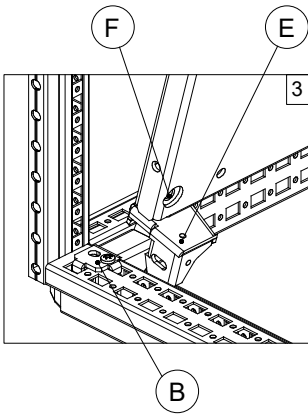
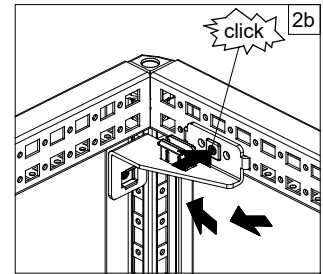
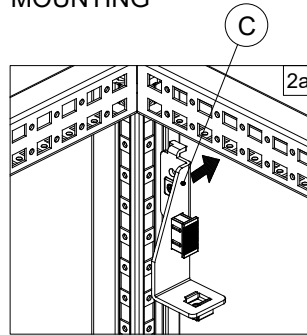

D Torque 4.5-5 Nm

UNMOUNTING

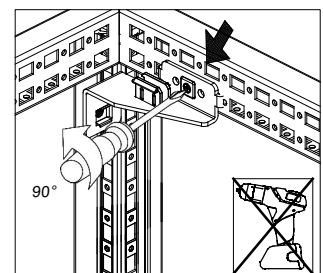
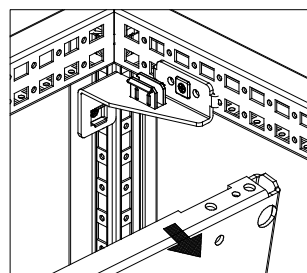
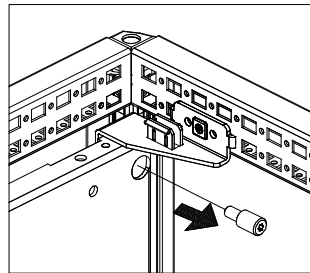
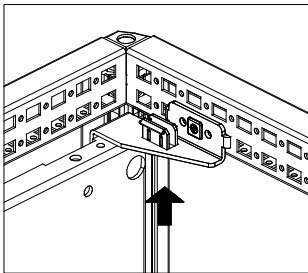



SPM

Ref.	Pic.	Qty.
A		0/1
B		6/8/9
C		6/8/9
D		2

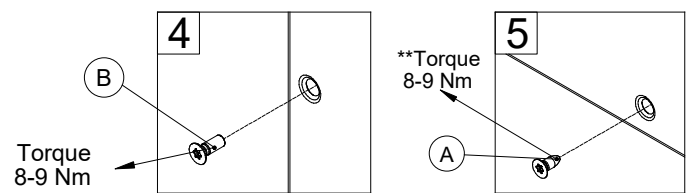
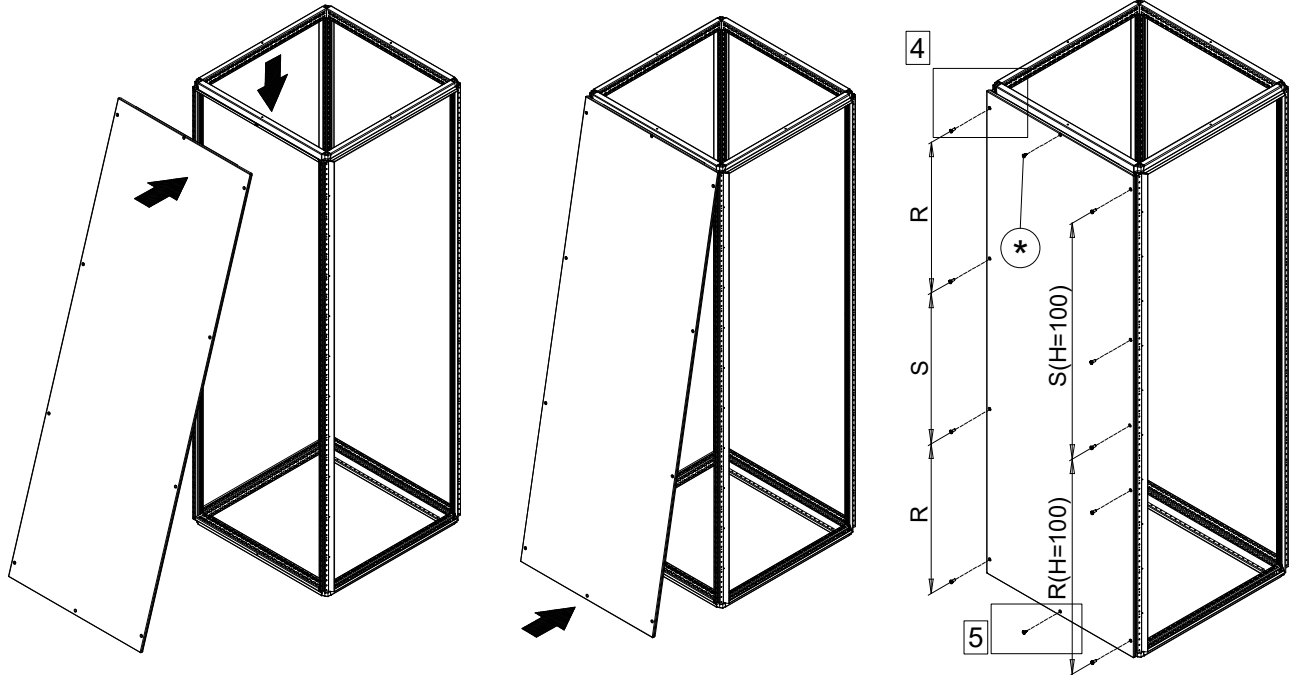
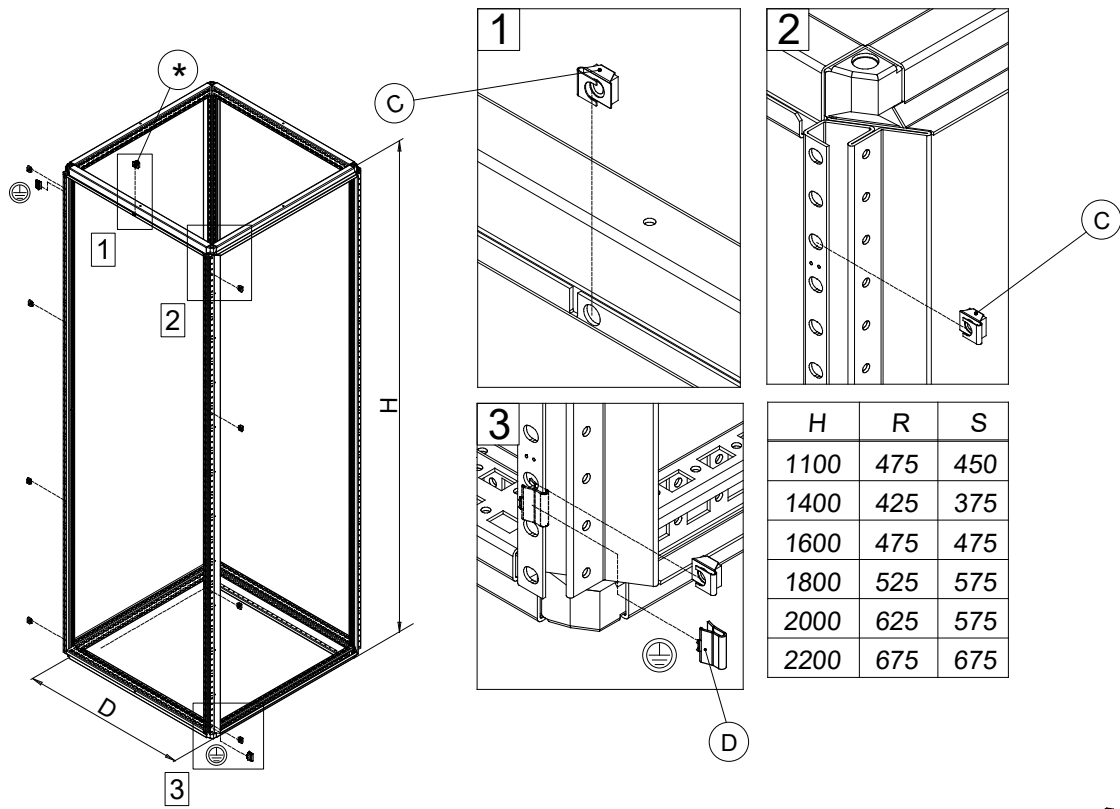

* - Used only on enclosures 800mm deep and above.

** - Torque value for first tightening. For following tightening, torque value recommended is 4-5 Nm.





Ref.	Pic.	Qty.
A		8
B		6
C		12
D		6

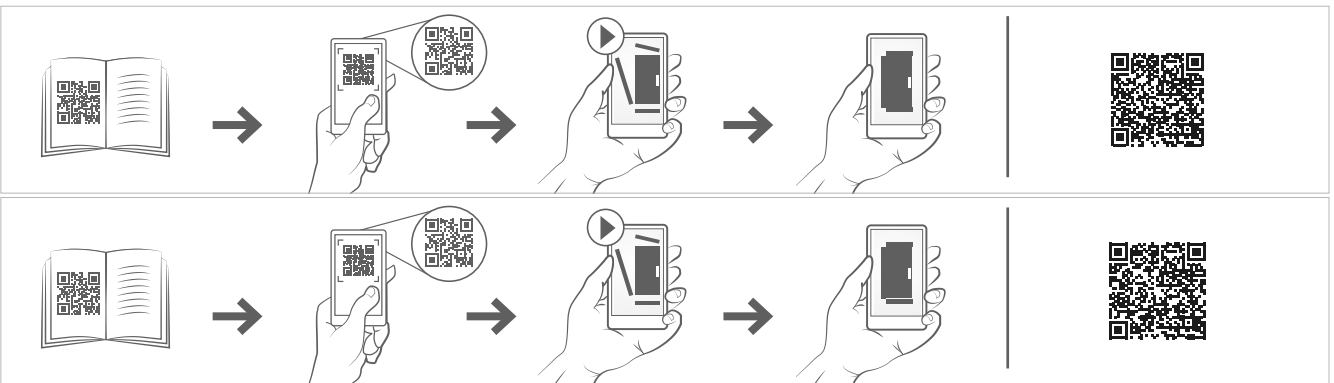
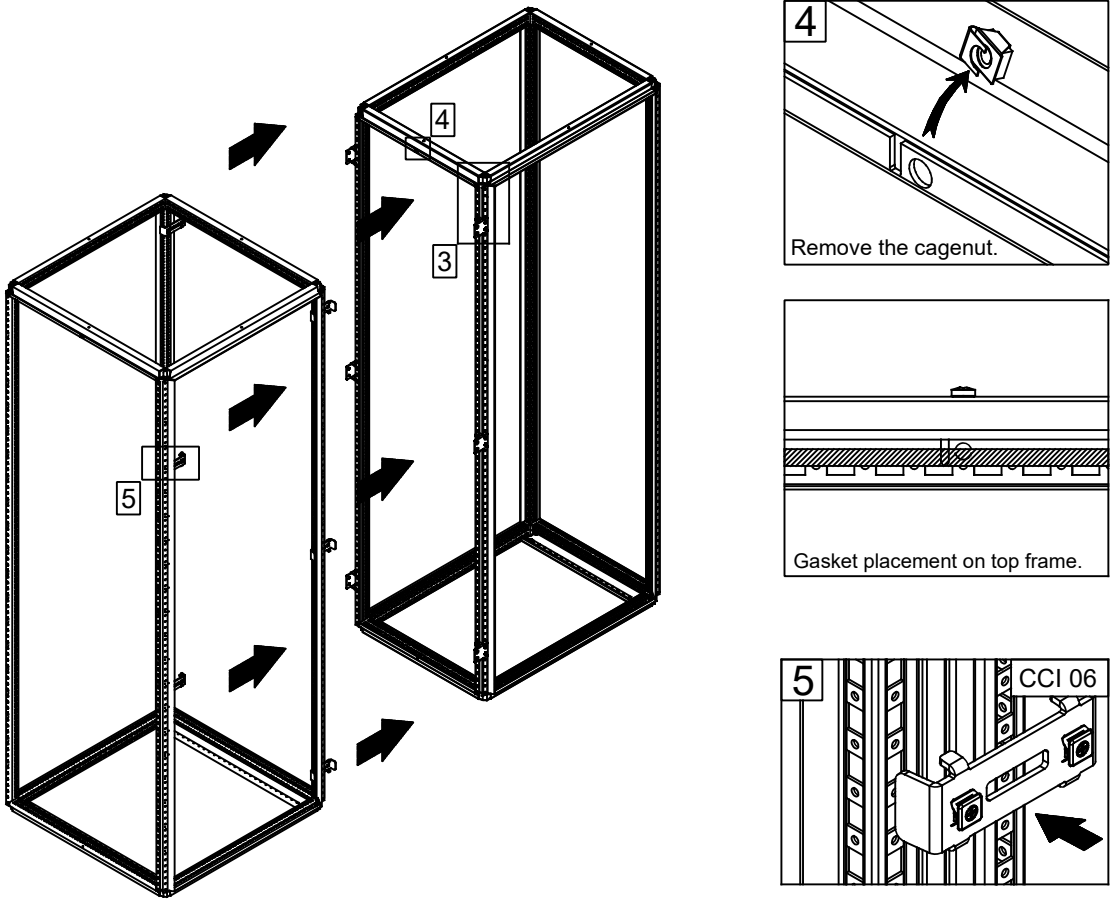
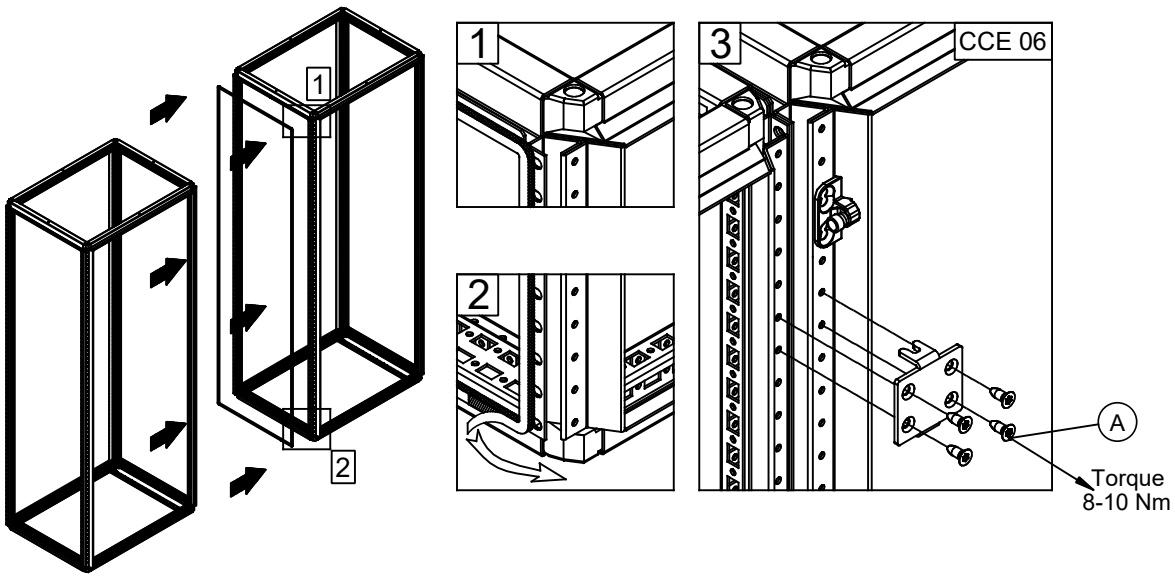



Ref.	Pic.	Qty.
A		4
B		4
C		2
D		4

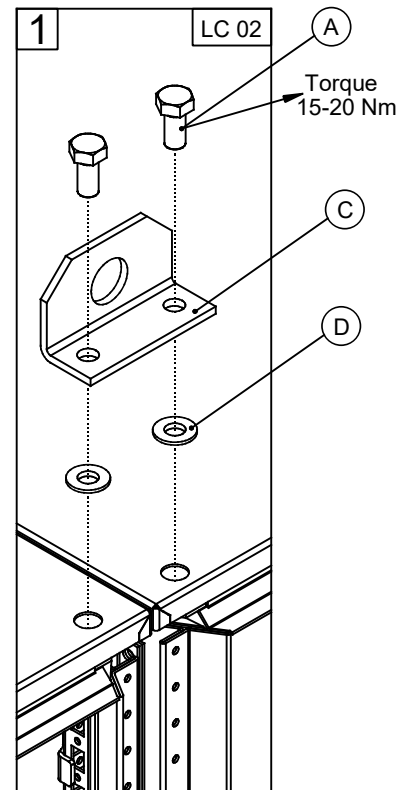
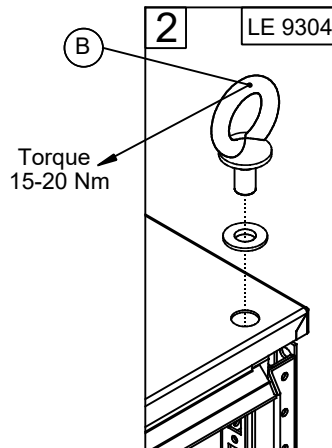
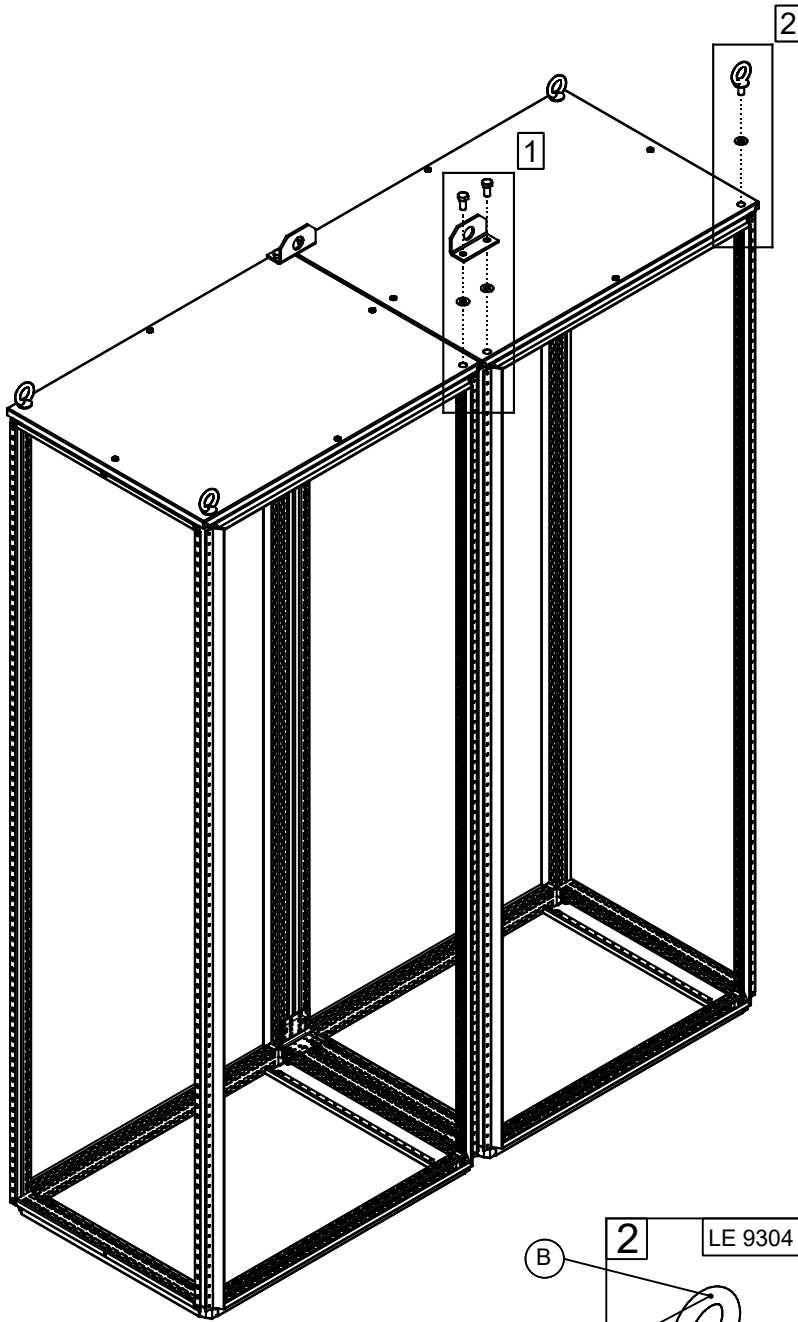



CCM 04

Ref.	Pic.	Qty.
A		4
B		8



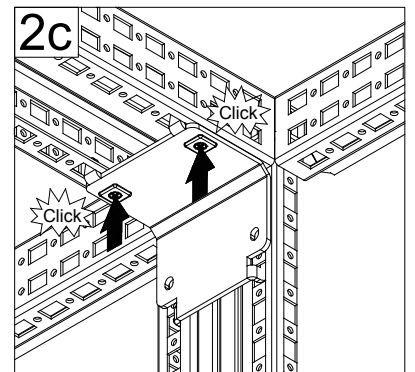
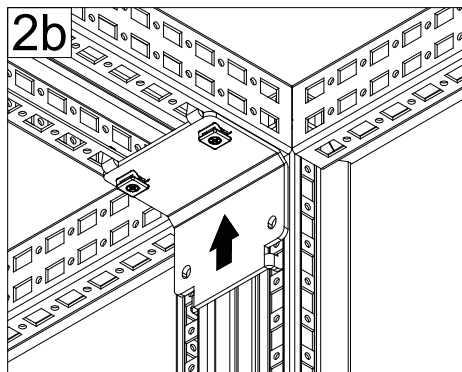
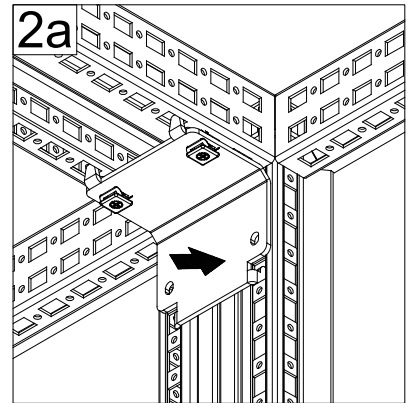
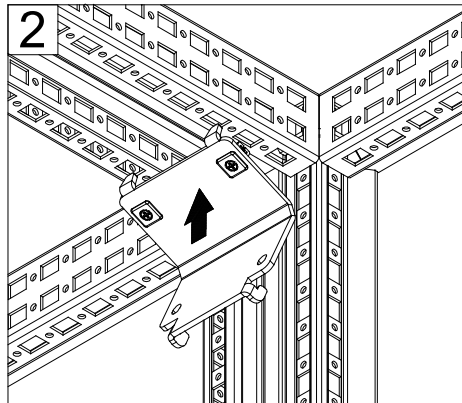
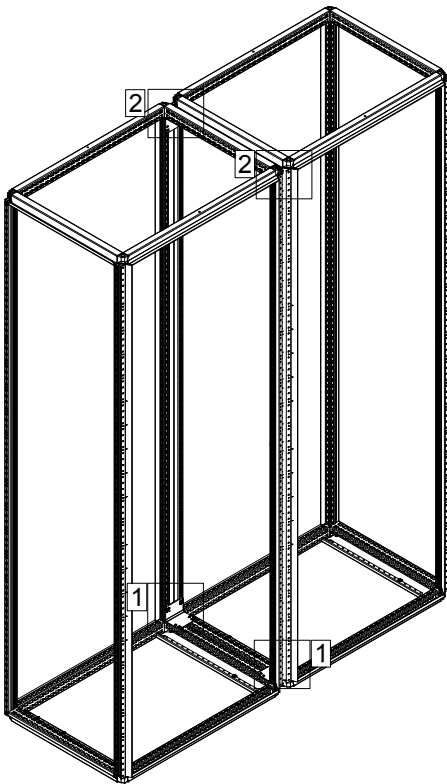
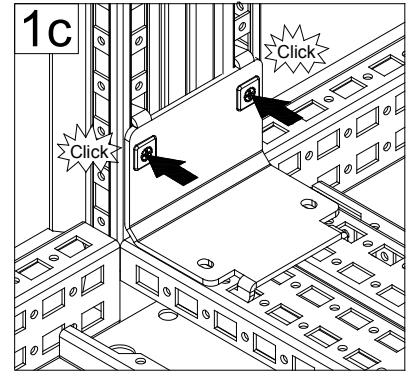
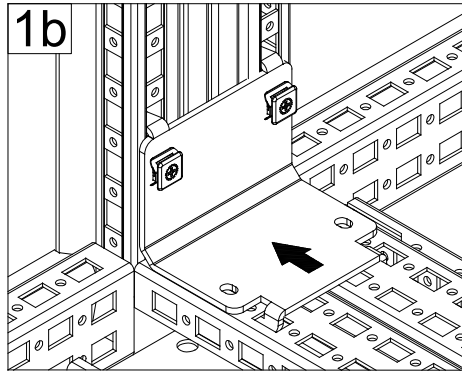
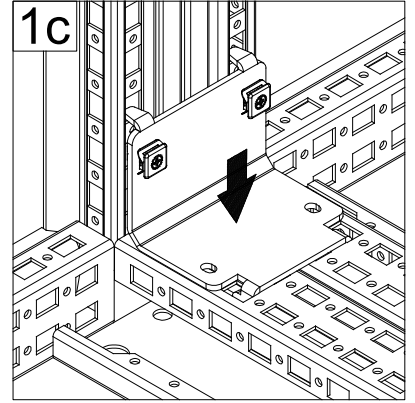
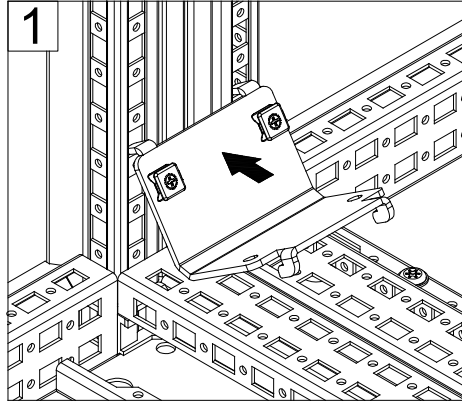
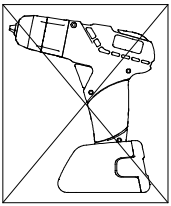
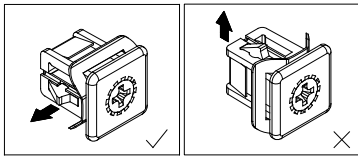
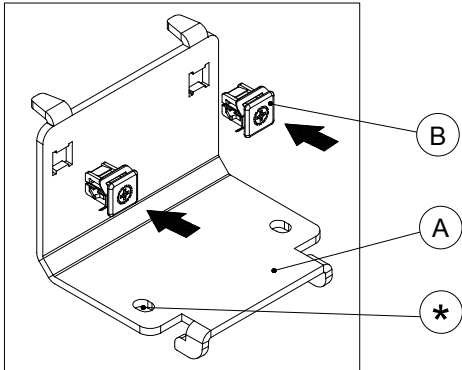

MOUNTING

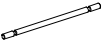

Note: It is mandatory for all four brackets to be installed at all four corners !

* The fixation holes can be used to better fix the bracket to the frame, using cage nuts and screws !

MPF

Ref.	Pic.	Qty.
A		1
B		1
C		2
D		2

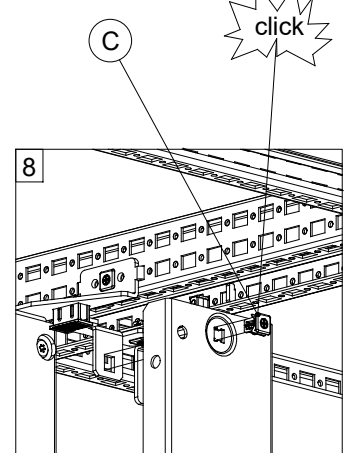
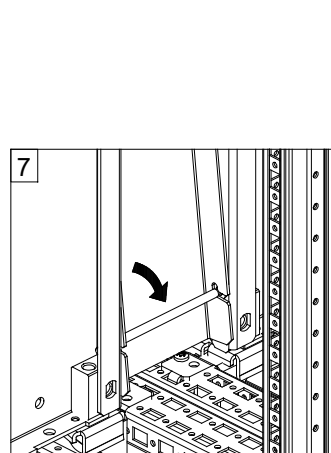
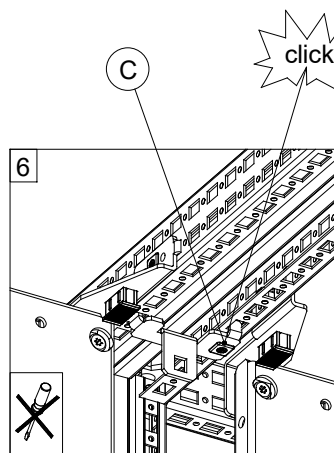
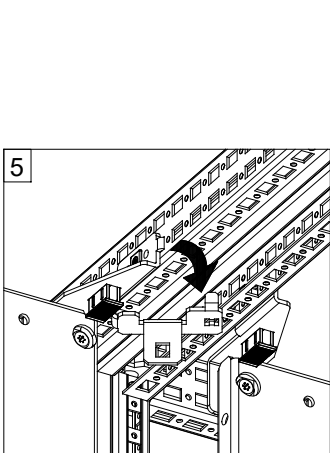
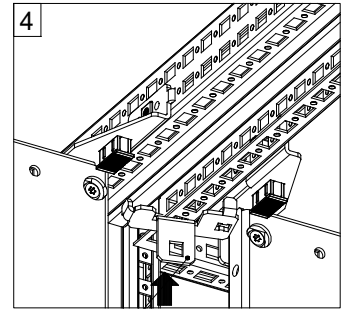
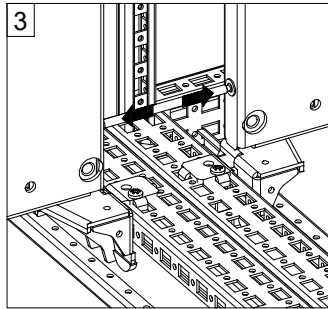
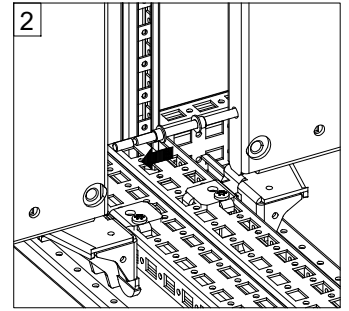
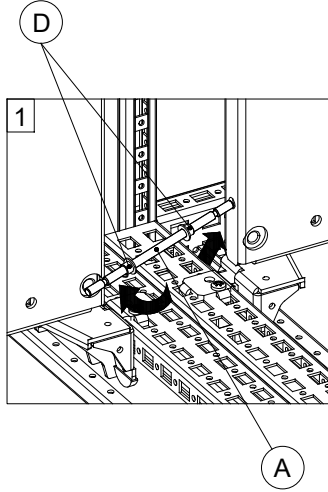
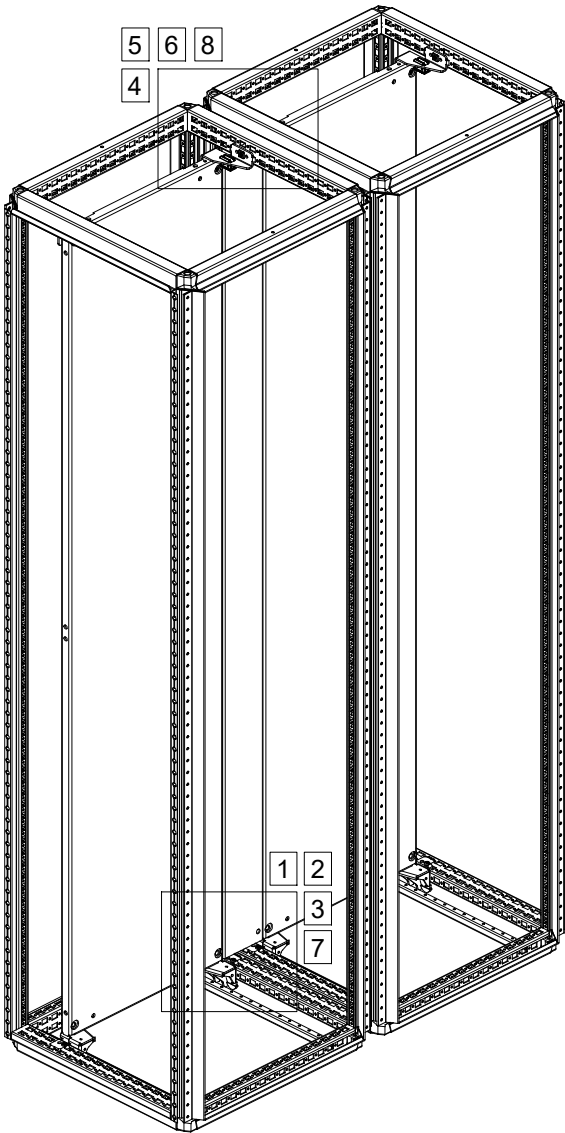

Back view



DHN 180

Ref.	Pic.	Qty.
A	 M6x12	8

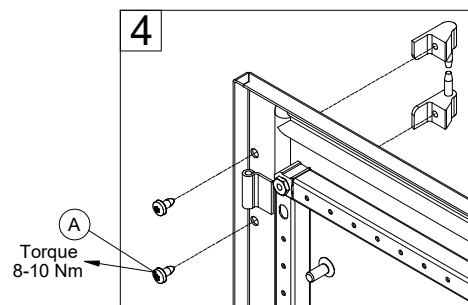
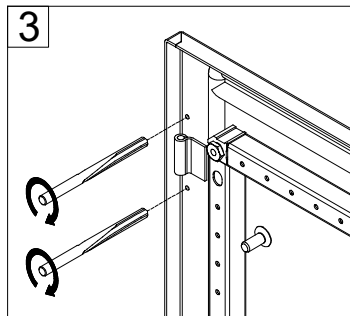
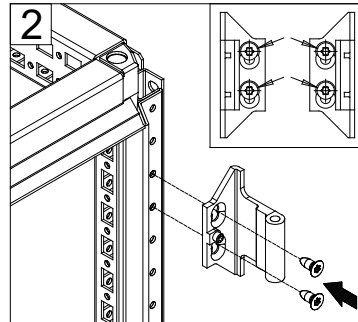
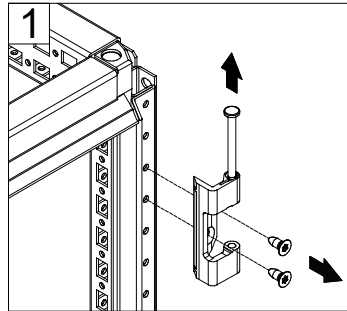
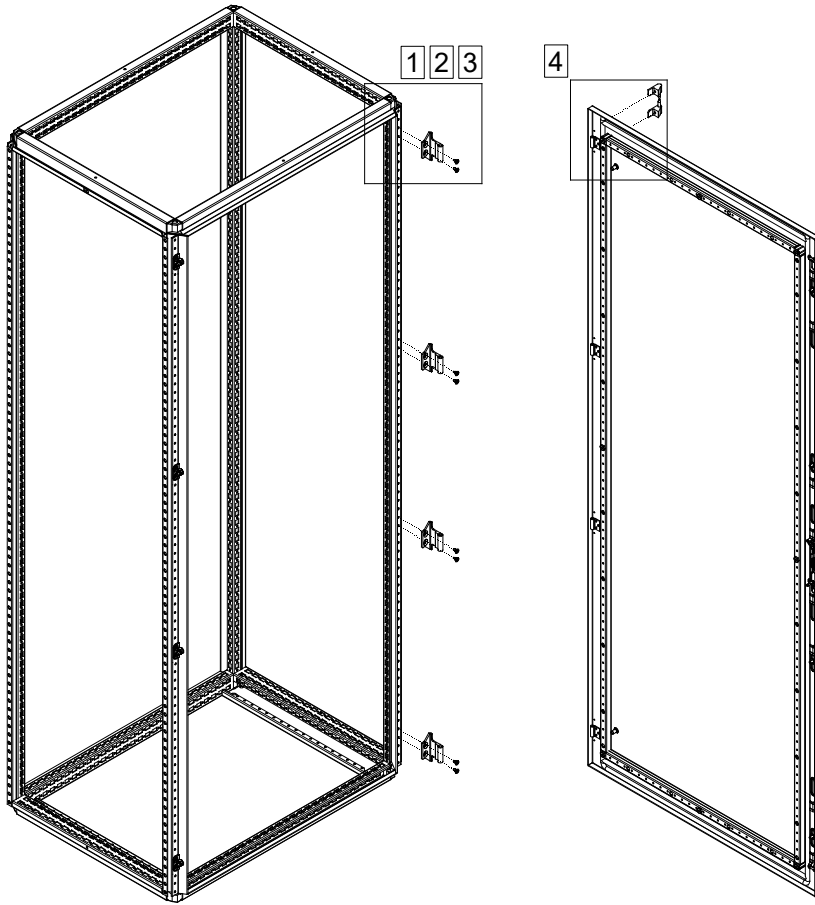
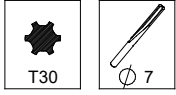



T30



SW3

DHN 180 DOOR ADJUSTMENT

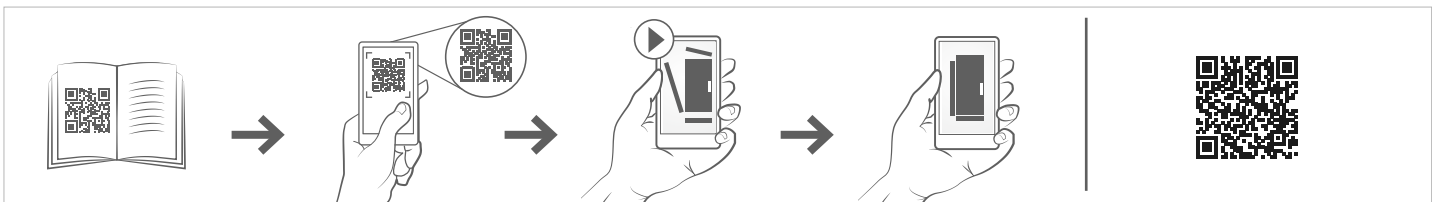
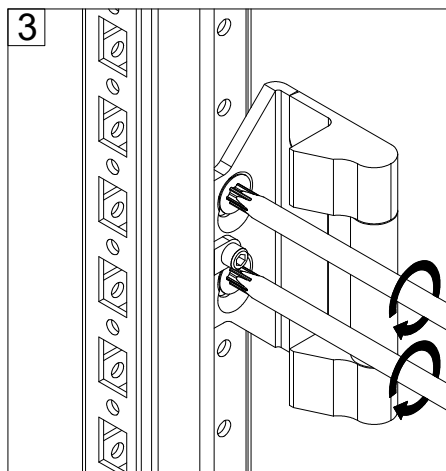
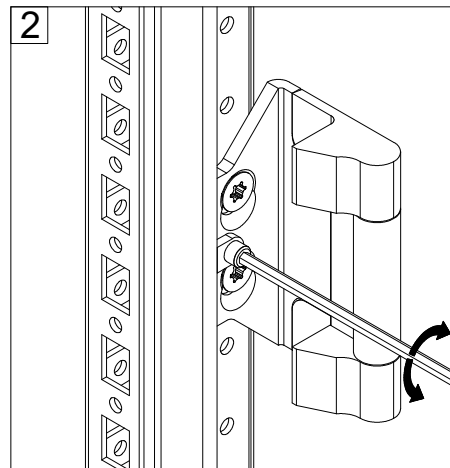
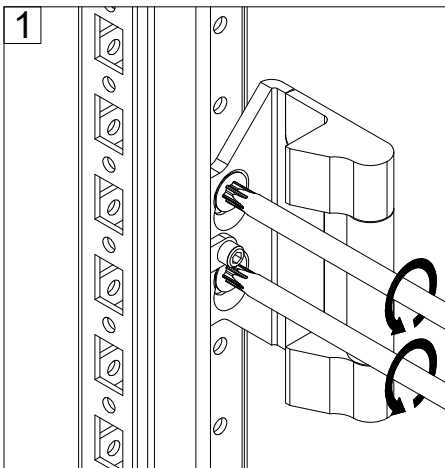
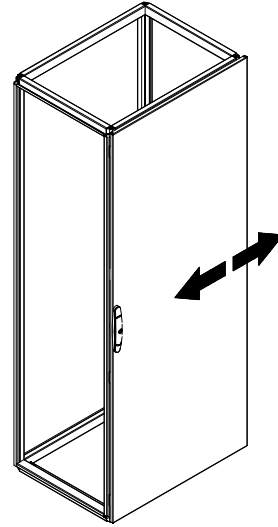
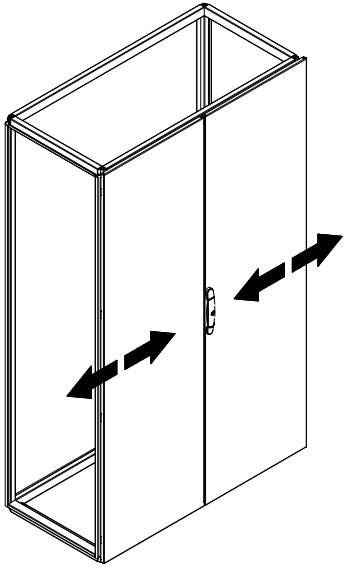

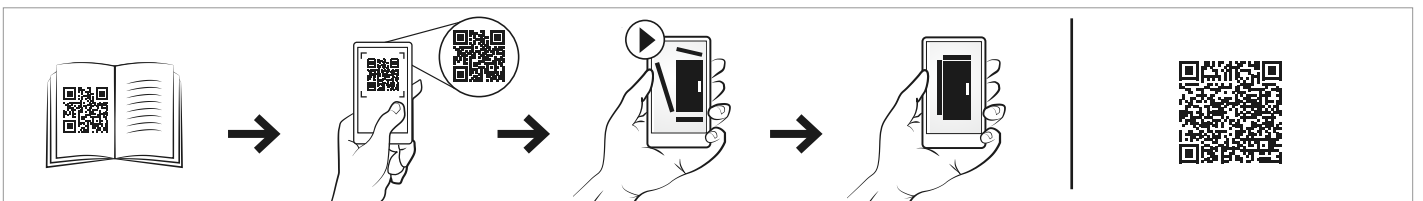
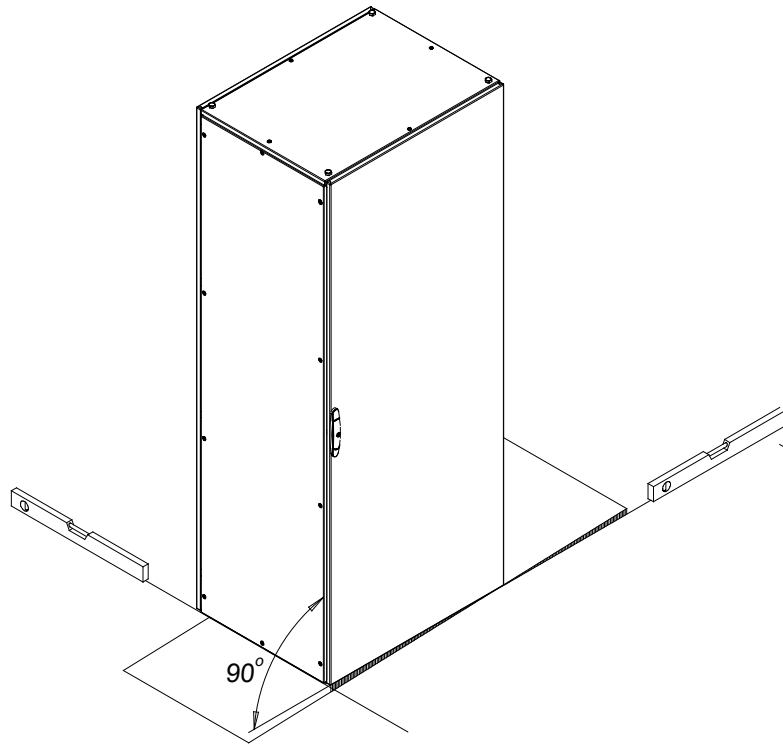
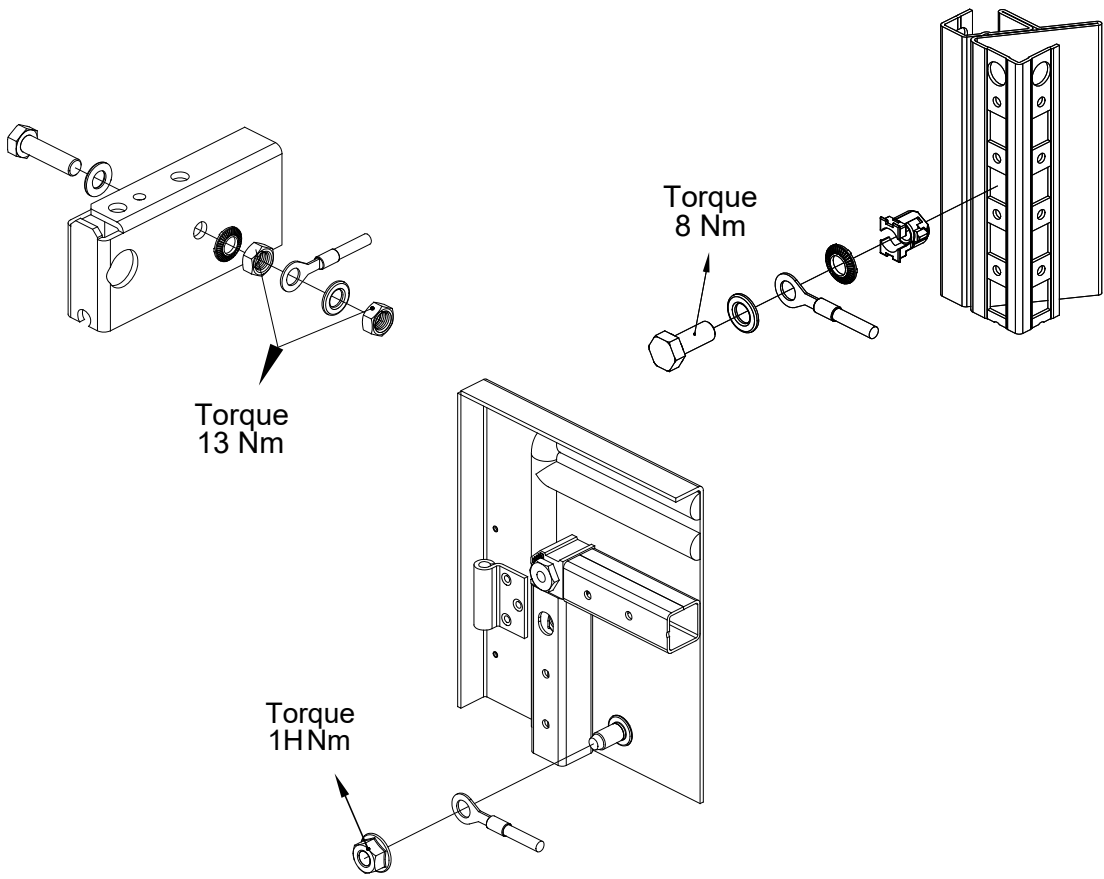

CNM

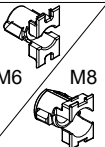
Ref.	Pic.	Qty.
A		1

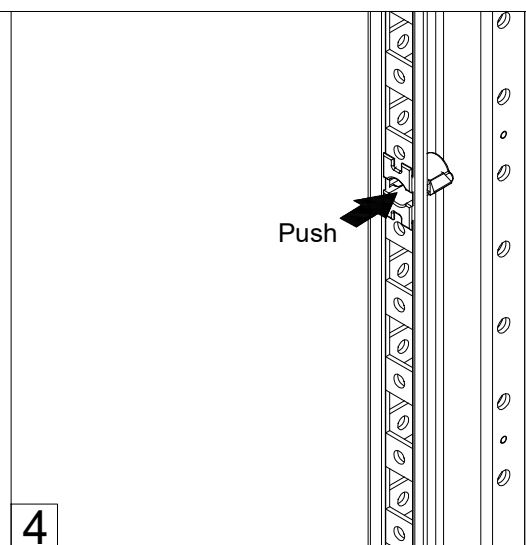
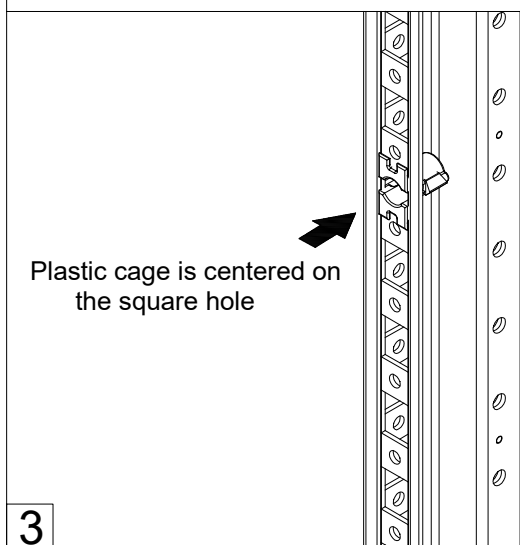
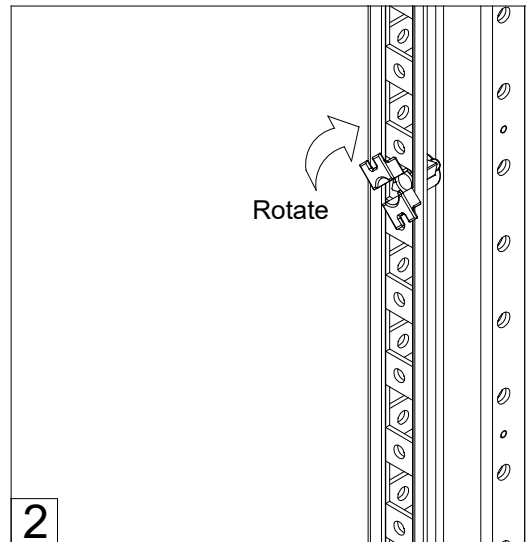
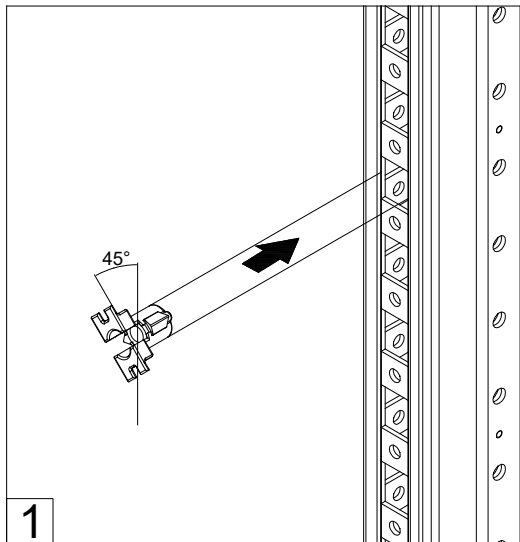
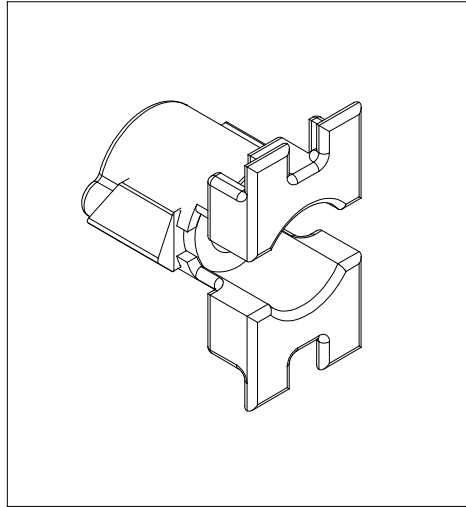

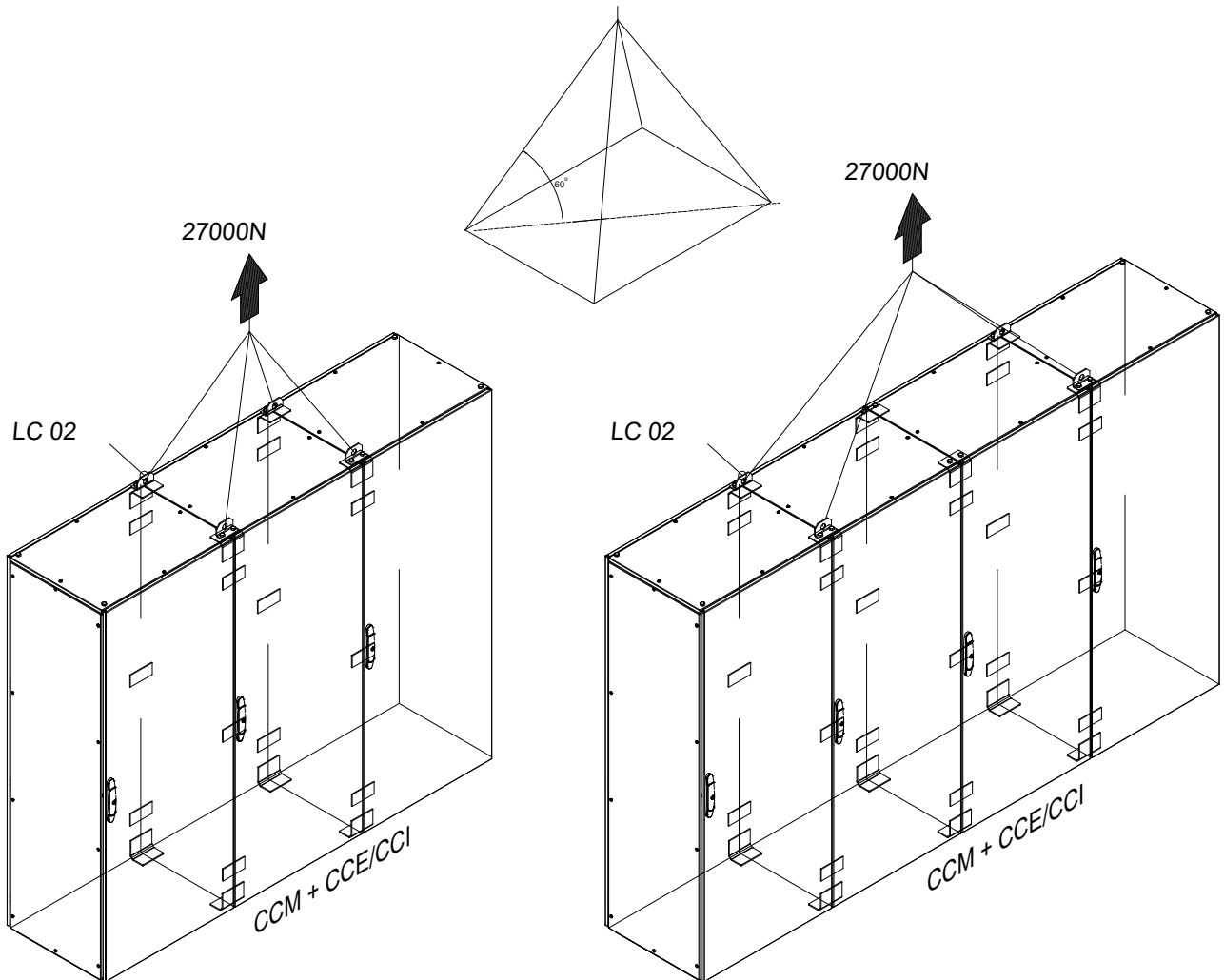
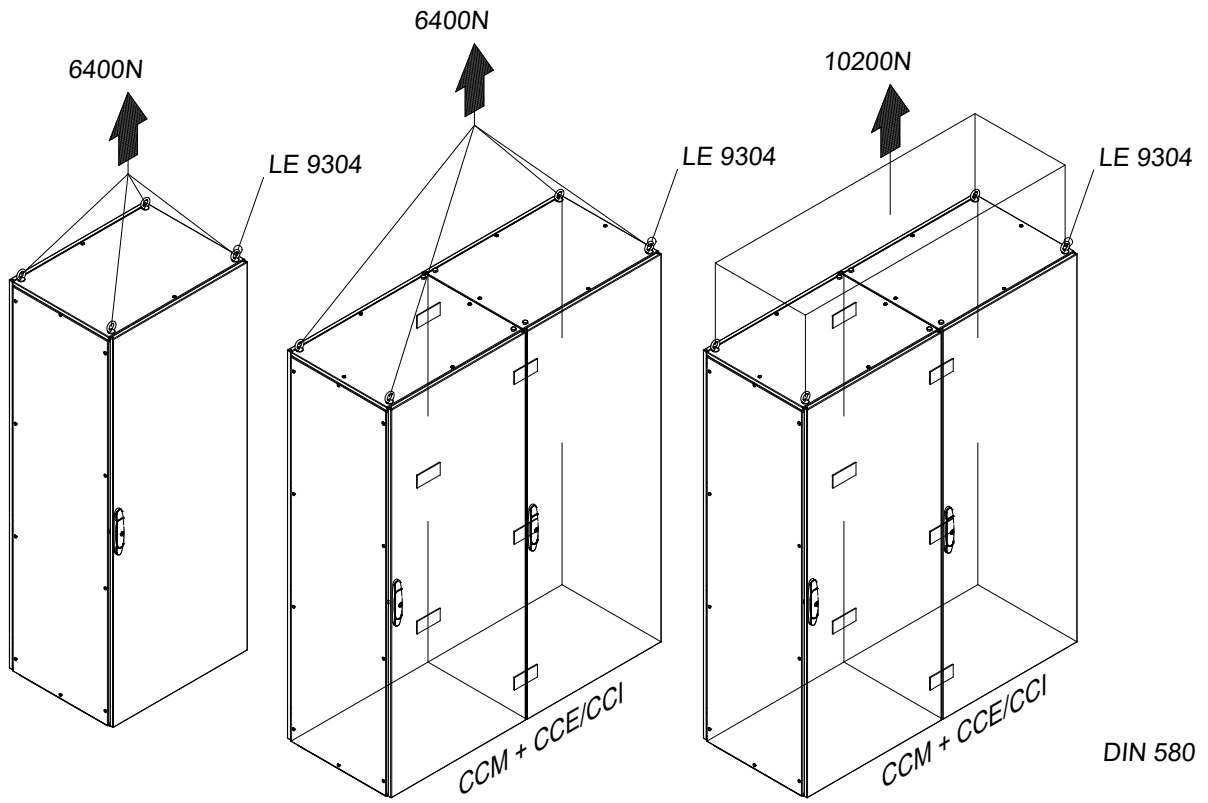



MCM

Mousepad RH into LH

